



# OIL DROPS

The Journey



By Eng. Fahad Al-Dhamen



Profile of author  
**Fahad Al- Dhamen,**  
Team Leader HSE (D&T)  
Kuwait Oil Company, Kuwait

Mr. Fahad Al-Dhamen graduated with a Bachelor of Science in Petroleum Engineering from the University of Southwestern Louisiana, (currently named ULL – University of Louisiana at Lafayette), USA. He has more than 21 years of experience in upstream - Oil and Gas sector. His experience is in the field of Health, Safety & Environment (HSE) Management of land drilling operations, Rig deployment programs, and Drilling Engineering services in compliance with Operational & HSE procedures.

Presently, he is working as a Team Leader of HSE Team for Drilling & Technology (D&T) Directorate, Kuwait Oil Company. He played a key role in implementing several HSE Initiatives & programs in line with ISO 14001 & OHSAS 18001 in Drilling & Technology Directorate. He presented various technical papers in IADC and SPE regional, international Conferences and also a HSE member of GCC Oil Companies Technical Exchange Committee.



# Acknowledgment

*First and foremost, I would like to thank God for everything and in giving me the opportunity to work on this book and contribute something to my work community and country. I do hope that this book will be of value to newcomers in the oil industry and to anybody from a non-oil and gas industry background.*

*I am especially thankful to my mother, who passed away while I was working on this book, for her never-ending support and encouragement to always do things at my best level. I am deeply thankful to my wife, who has supported me and provided me with the right atmosphere to work. I am also deeply thankful to my family, who like my mother and my wife, are always there for me, giving support and extending their patience throughout the process.*

*Lastly, I would like to extend my appreciation and thanks to those who helped me even in the smallest ways in making the completion of this book possible.*





# Contents

Introduction .....	06
History of Oil.....	07
Origin of Hydrocarbons .....	11
Exploration.....	14
The Journey of Oil .....	25
Well Planning .....	27
Pre-Drilling Operations.....	30
Drilling Operations .....	33
Rig Components .....	55
Drilling Rig Types .....	83
Drilling Fluids .....	90
Solids Control.....	96
Casing .....	98
Cementing .....	102
Companies .....	104
Rig Personnel .....	105
Drilling Problems .....	110
Calculation.....	116
Completion and Production.....	140
Refinery & Petroleum Products .....	151
Petrochemical Products.....	157
Transport and Export .....	165
Health, Safety and Environment.....	169
Conclusion .....	181
Appendixes.....	182
References.....	223



# 1. Introduction

Crude oil remains one of the most important sources of energy in the world. Despite the latest emerging renewable energy, crude oil is still at the top due to its level of sustainability, available production facilities and current technologies. With this in mind, the burden rests on all companies committed to oil drilling to further expand their scope to attain maximum production along with the lifespan of a well. Among these burdens are efforts and means exerted in protecting the environment while exploring and drilling for this so-called “black gold.”

This book intends to give a simple orientation to new employees and readers with an interest in the oil industry. It aims to create an overview of the main processes and equipment, in both the upstream and downstream ends.

The book, in its simplest form, journeys from the source of hydrocarbons to drilling, production, and to its end products. The book maps the web of industries involved in oil, its intricacies, how one is connected to another and its impact on oil production.

The book has been compiled from various books and online resources. The book also contains many photos to give the reader an impression of the typical facilities or equipment on a drilling rig. Photo sources are given under every picture.

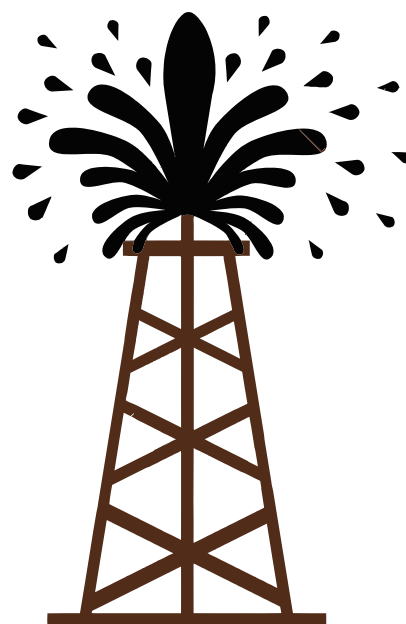



## 2. History of Oil

### Introduction

Oil has been known by man for thousands of years. It was first utilized by humans around 5,000 BC. Oil was generally used to keep fires ablaze. It was also used in warfare.

In the Middle East (around 4,000 BC) people obtained the oil that seeped to the surface to waterproof boats and as an adhesive in the construction of buildings and roads. Crude oil was also used for lamp and heating oil in China (1,000 B.C.). The Byzantines used crude oil to produce a flame-throwing weapon known as Greek fire. Oil also was used for street paving, medicine, waterproofing, lighting, and more.

The demand for oil increased due to oil's several usages, mainly for lighting by the mid-1800s. In the 19th Century, people relied on whale hunting to obtain whale oil, but it was so scarce that only the wealthy could afford it. There was a need to replace whale oil with a new source of energy.

Kerosene eventually replaced whale oil as the illuminant of choice and created a new market for crude oil.

The quest for a better source of energy still remained and it was answered in Baku, Azerbaijan in 1848. In Baku, which was known for its natural gas seeps, the first modern well was drilled by Russian engineer F.N. Semyenov. It was a very shallow well, only about 69 feet. By the 1860s, 90% of world oil production was from Azerbaijan, which is why Baku was called the "Black City."

In 1854, the first oil wells in Europe were drilled about 30 to 50 meters deep at Bębrka, Poland by Ignacy Lukasiewicz.

Meanwhile, the Pennsylvania Rock Oil Company hired a railroad contractor named Colonel Edwin Drake to carry out the drilling operations in the United States. In 1859, Drake struck oil near Titusville, Pennsylvania. The well was about 69 feet deep and it produced close to 15 barrels per day. Pennsylvania become responsible for half the world's oil production by 1901.



Fig 3.1 – Drake's Well

Source: [http://www.priweb.org/ed/pgws/history/pennsylvania/triumph\\_hill.html](http://www.priweb.org/ed/pgws/history/pennsylvania/triumph_hill.html)

In January, 1901, a prospector named Anthony Lucas, struck oil while drilling on Spindletop Hill, about 10 miles south of Beaumont, Texas. The well produced a large amount of oil - about 48,000 barrels.



Fig 3.2 – Spindletop, 1901

Source: The American Institute



With the Spindletop Hill oil discovery, people began to realize the true potential of oil. Many oil companies started their business to drill for oil. By 1910, significant fields were being developed in Iran, Sumatra, Venezuela, Peru, and Mexico. Nevertheless, the United States of America remained the world's foremost producer. In the mid-1950s, the production of petroleum outside the United States of America passed that within the United States of America.

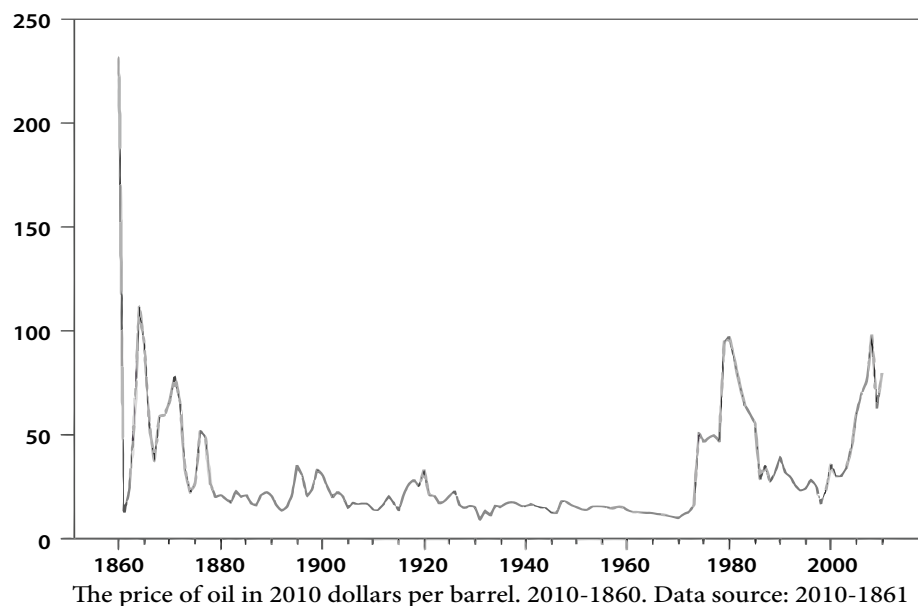

Fig 3.3 – Oil Prices Timeline

Source: <http://marginalevolution.com/blog/wpcontent/uploads/2012/02/real-oil-price.jpg>

## Brief History of Kuwait Oil Company

Kuwait Oil Company was established in 1934 by the Anglo-Persian Oil Company, which is known today as BP (British Petroleum), and Gulf Oil Corporation, now known as Chevron.

By 1938, oil was found in commercial quantities at Burgan Field. In June of 1946, His Highness Sheikh Ahmad Al-Jaber Al-Sabah, the late Amir of Kuwait, inaugurated the export of Kuwait's first crude oil shipment.



Shortly after, new fields were developed and export facilities were expanded, resulting in the construction of the North and South Piers, the Sea Island, and the Single Point Mooring.

In 1975, the Kuwait Government took 100% control of Kuwait Oil Company, and by 1980, the Kuwait Petroleum Corporation was established to bring all state owned oil companies under one entity.

Kuwait's petroleum and other liquids production and consumption, 1987 - 2013

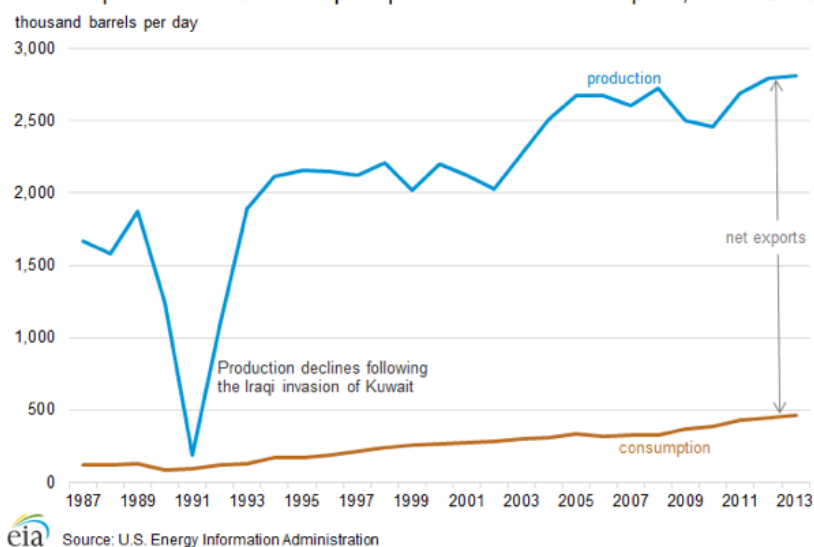

The Iraqi invasion of 1990 devastated KOC facilities. However, within months of Kuwait's liberation in February of 1991, production gradually returned to full capacity.

Super light crude oil was discovered at the Sabriya Field in 2005. The discovery of the API 52 crude oil represented a great leap forward for the Company's exploration abilities..

In 2006, gas was discovered in the deep Jurassic reservoirs at Rahiya, Mutriba, Um Niga and other fields throughout Kuwait. These discoveries fulfilled a long-standing Kuwaiti dream of becoming self-sufficient in gas that can be used for power generation.

In 2011, KOC successfully achieved its goal of reducing gas flaring to approximately 1%. Compared to gas flaring levels of as high as 17% just a few years earlier, this represented a major accomplishment for KOC.

Today, KOC continues to live up to its stated mission of exploring, developing and producing Kuwait's hydrocarbon resources for its customers around the world in a way that is environmentally sound and economically viable.



# 3. Origins of Hydrocarbons

**Introduction:** A hydrocarbon is an organic compound consisting mostly of hydrogen and carbon. Each compound consists of hydrogen and carbon atoms. As the name suggests, these are large molecules made up of hydrogen atoms attached to a backbone of carbon. (Fig. 2.1)

Hydrocarbons can be in the three states of matter: gases, liquids and solids.

Hydrocarbons are very important because they are one of the Earth's most important energy resources. The predominant use of hydrocarbons is as a combustible fuel source. The role of hydrocarbons in human development cannot be underestimated. Essentially, without them the modern age would not have manifested.

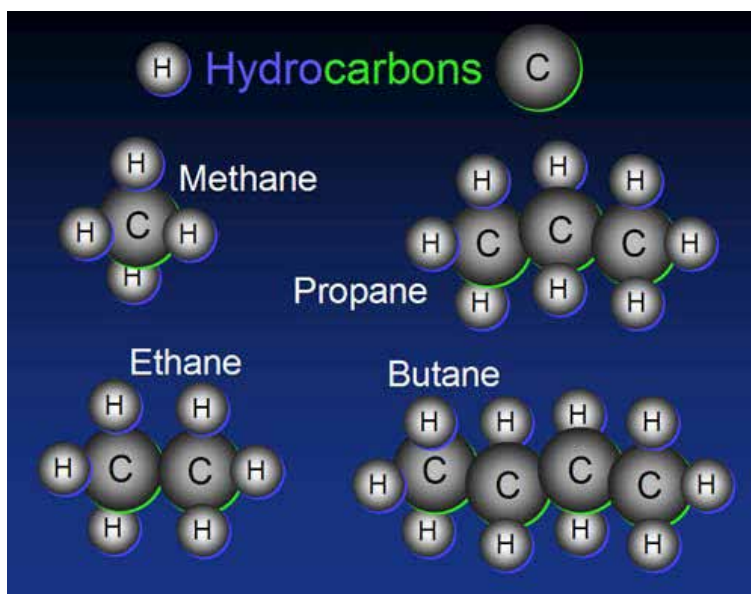

Fig 2.1 – Hydrocarbons

Source: <http://www.universetoday.com/83833/hydrocarbons/>

There are many theories on the origin of hydrocarbons which can be classified into two categories, organic theories and inorganic theories.

The organic theory has been accepted more than the inorganic theory because it has more supporting evidence. The organic theories state that hydrocarbons are the result of the decomposition and transformation of plants and marine animals under the impact of high temperature and high pressure conditions. The depth also plays as a factor as well.



Oil is a fossil fuel that is formed from the remains of tiny plants and animals, known as plankton that died in ancient seas between 10 million and 600 million years ago (Fig. 2.2). The plankton fell to the bottom of the sea and after decaying, the organisms formed sedimentary layers. In the layers, little or no oxygen is present and this allows microorganisms to break down the remains into carbon-rich compounds that form organic layers.

The organic material is mixed with the sediments to form fine-grained shale, or source rock. As the sedimentary rocks layer, they exert extreme heat and pressure to distill the organic material into crude oil and natural gas (Fig. 2.3). The oil then flows from the source rock and accumulates in thicker, more porous limestone or sandstone known as reservoir rock.

When the earth moves, the oil and natural gas is trapped in reservoir rocks, which are between layers of impermeable rock, or cap rock. The whole process takes millions of years.

Most oil and natural gas around the world is found in layers that were deposited during the Mesozoic era about 250 million years ago.

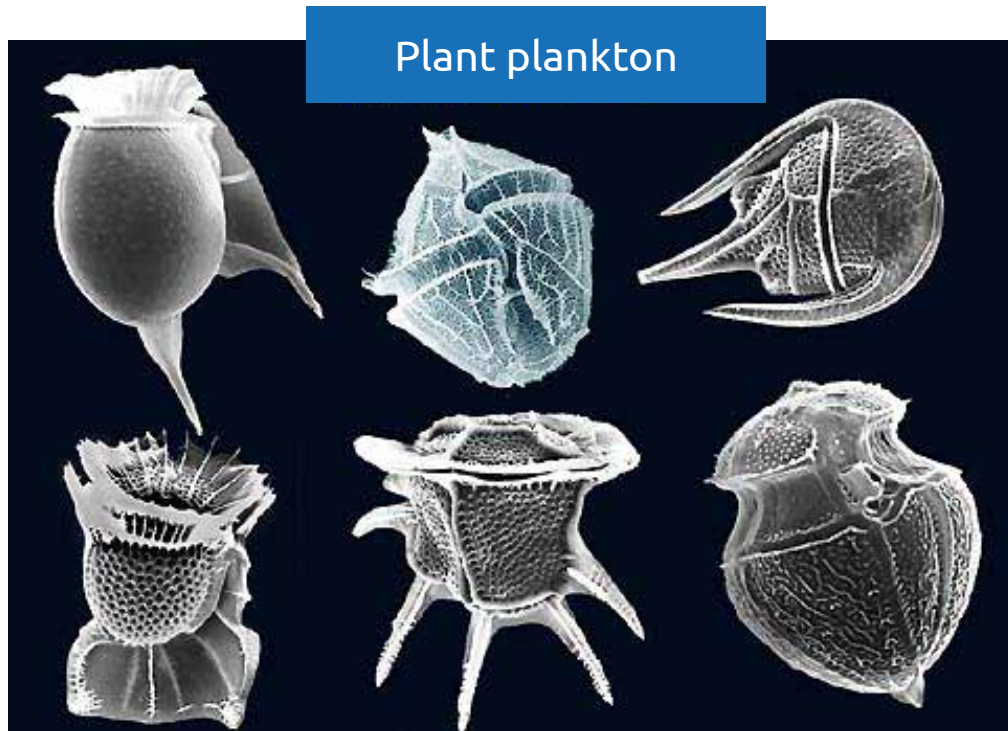

[en.wikipedia.org/wiki/Image:Ceratium\\_hirundinella.jpg](https://en.wikipedia.org/wiki/Image:Ceratium_hirundinella.jpg)



Animal plankton

en.wikipedia.org/wiki/Image:Copepod.  
cache.eb.com/eb/image?id=93510

Fig 2.2 – Plankton

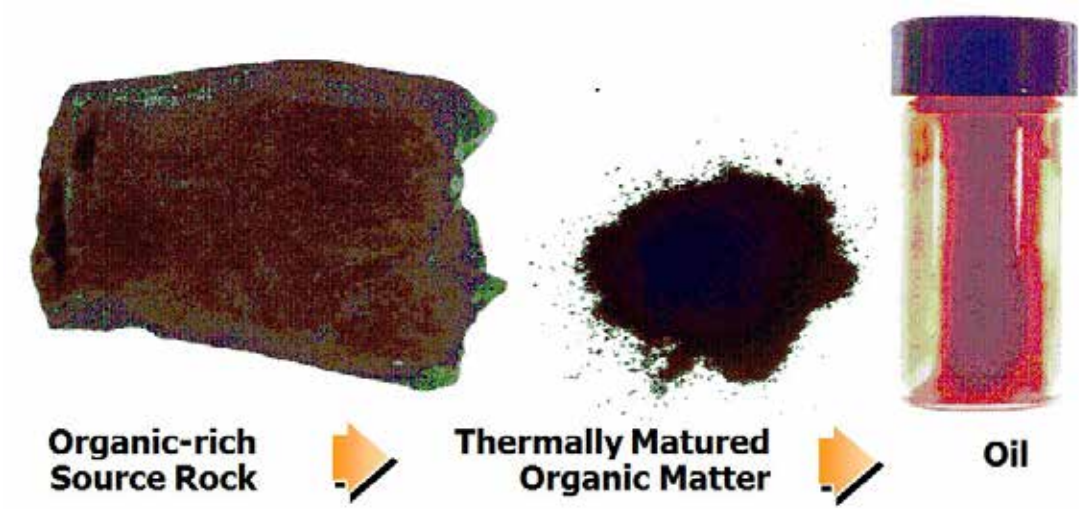

Fig 2.3 – Organic Source Rock to Oil



# 4. Exploration

## 4a.GEOLOGY

### Introduction

There is strong relationship between geology and drilling. Geology is the study of the earth's formation structure and the earth as a whole. Geological information draws the roadmap for the drilling engineers to plan prior drilling the oil well. Understanding the information such as nature and the material of the formation to be drilled is essential for successful drilling.

### The Rock Cycle

Rocks are the most common material on Earth. Rocks consist of one or more minerals. There are three types of rocks based on how they formed:

#### 1. Igneous

They are primary rocks. They are formed from molten rocks which is called Magma.

Pegmatite, Obsidian, and Basalt are examples of igneous rocks.

#### 2. Sedimentary

They are secondary rocks. They are formed from sediments and/or minerals which were part of pre-existing rocks.

Sedimentary rocks sources can be igneous, metamorphic, and previously existing sedimentary rocks.

Carbonate, sandstone, and shale are examples of sedimentary rocks.

#### 3. Metamorphic

They are formed from sedimentary rocks, igneous rocks or previously existing metamorphic rocks. Metamorphism is the change from one state to another.

Metamorphic rocks undergo at least one of these two processes: Change in temperature, change in pressure.

The rock cycle (Figure 4.1) explains how the three rocks types are related to each other and how Earth processes change a rock from one type to another through geological time.

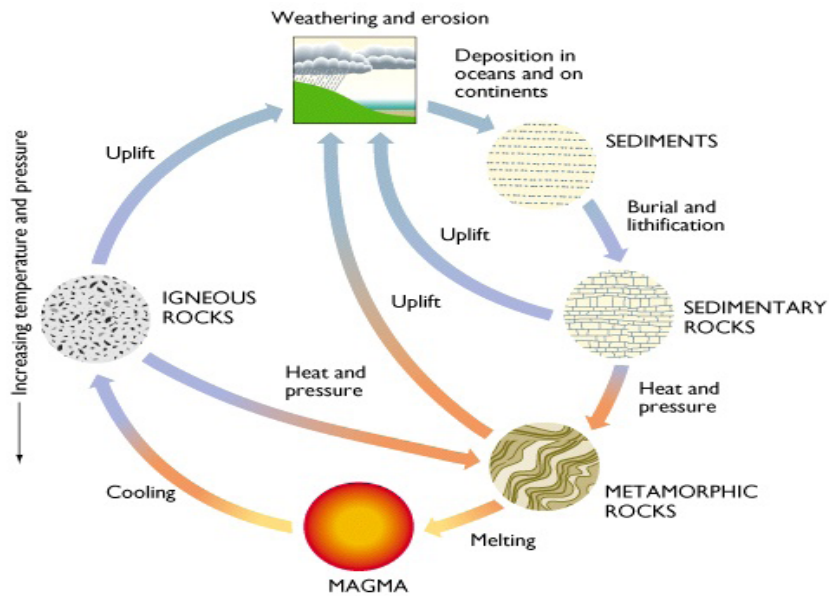

Fig 4.1 – Rock Cycle

Source: <http://www.daukas.com/Geoscience/MAtour/images/RockCycle.jpg>

Plate tectonic movement is responsible for recycling of rock materials and is the driven force of the structural geology. Structures vary in sizes from hundreds of kilometers to millimeters.

## Petroleum Reservoir

A petroleum reservoir or oil and gas reservoir is a subsurface pool of hydrocarbons contained in porous or fractured rock formations.

Oilfields and gas fields are areas where hydrocarbons trapped in permeable reservoir rocks. The fluid migration toward the surface is stopped or slowed down by impermeable rocks that act as a seal.

The hydrocarbons formed under a set of conditions such as high temperature (between 100F - 350F) and high pressure caused by the depth of the formation.

The higher the temperature, the higher the gas proportion forms in the reservoir.

Reservoir rock must be porous which means it has tiny holes through which oil may flow.

The porosity of a formation determines its capacity for reservoir fluids. Porosity varies depending on the formation. Porosity is defined as the



relative amount of void space existing within a rock. Porosity measures the percentage of overall rock volume. It can be expressed in percentage (%).

- The greater a rock porosity, the more fluids it is able to hold.
- The greater the formation depth, the less the value of the rock porosity due to increasing in overburden pressure.

The reservoir rock has to be permeable. The pores in the reservoir rock are connected which permits the hydrocarbons to flow and migrate.

The ability of reservoir rock to transmit fluids is called by the Permeability which can be measured in Darcy or millidarcies unit.

The quality of reservoir rock can be determined by the reservoir permeability.

- Coarse-grained and well sorted reservoir rock gives good permeability.
- Fine-grained and poorly sorted reservoir rock gives poor permeability.

There is a great relationship between porosity and the permeability of the reservoir rock. The greater the porosity, the greater permeability is.

Sandstone, limestone and dolomite are common examples of reservoir rocks.

A suitable reservoir rock must therefore be porous, permeable, and contain enough hydrocarbons to make it economically feasible for the operating company to drill for and produce them.

The migration of hydrocarbons is a very slow process; it takes a very long time. Hydrocarbons migrated to the sea floors and land surfaces around the world.

## Geological Structures

Sedimentary rocks are deposited in horizontal layers called Strata or Beds. The formation rocks are subjected to forces that led to deformation such as folds.

There are three types of traps depending on the way the cap rock structure was formed: Structural, Stratigraphic and Combination traps.

The earth's crust rock movement leads to form folds, faults and salt domes which is known as **Structural traps**.



There are different types of folds; the most common types of fold are Anticlines (Arches) and Syncline (Troughs).

Fault traps are caused by the movement of the rock along a tectonic fault line to form a trap.

Salt Dome traps are formed by underground salt movement.

**Stratigraphic traps** (fig 4.2) result from sedimentation of different rock strata. The sedimentation process and erosion of layers of rock affect the trap formation. Common types Stratigraphic traps are of Unconformity Traps, Pinchout Traps (Coal Reef), and Lens Traps (Sand Lens).

Having a combination of various types of traps is called **Combination traps**. Most crude oil reservoirs are a combination of different types of traps.

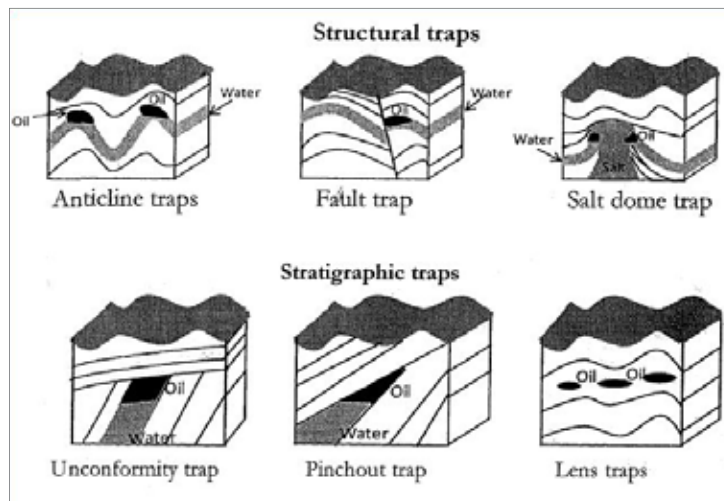

Fig 4.2 – Stratigraphic traps

Sources: Downey, Morgan. Oil 101. 1st ed. Wooden Table Press, 2009. 88-9 .Print.



## 4b. GEOPHYSICS

Exploration geophysics is an applied branch of geophysics using physical measurements acquired at or near the Earth's surface to deduce the physical properties of the Earth's subsurface. It is most often used to detect or infer the presence and location of economically useful quantities of oil and gas, but can also be used for mineral ore, geothermal and groundwater investigations. The main techniques used in exploration geophysics are:



- Seismic
- Geodesy / Gravity
- Magnetic
- Electrical
- Electromagnetic

Of the techniques listed above the seismic methods are the most widely used in hydrocarbon exploration as they offer the best compromise between cost-effective areal coverage and resolution of the relevant physical properties.

### Gravity Methods

Geodesy or measurements of gravitational acceleration, is a passive method in the sense that the Earth, like any physical body with a mass, exerts a gravitational pull. The local variations in the density of rocks cause minute changes in the gravity field. These density variations and their impact on the gravity field are relatively small compared with the effect of the background field of the Earth as a whole (often on the order of 1 part in 10<sup>6</sup> to 10<sup>7</sup>). The gravity field is constant (ignoring "earth tides") and can be approximately calculated assuming the Earth is an ellipsoid.

**Gravity Surveys Data Acquisition**

- High-Precision (Microgravity)**
  - Near surface-characterization
  - Improve seismic depth imaging
  - Mapping of karsts, buried channels, sinkholes
  - Mapping and monitoring of geothermal systems
- Low-Precision, Airborne**
  - Structural mapping
  - Mineral exploration
- Marine**
  - Measure gravity or compliance (bending of seafloor under pressure of intra-gravity waves, yielding Vs as a function of depth)

Above: Scintrex CGS Autograv  
Left: marine sweresion for seafloor measurements



Gravity prospecting is used as a reconnaissance tool in oil exploration. Although expensive, it is still considerably cheaper than seismic prospecting in covering large areas. However, this comes at the expense of much lower resolution in terms of the subsurface variations. Gravity data are also used to provide constraints in seismic interpretation through inverting for basement rocks and other large-scale gravity anomalies.

In mineral exploration, gravity prospecting usually has been employed as a secondary method, although it is used for detailed follow-up of magnetic and electromagnetic anomalies during integrated grav-mag surveys. Gravity surveys are sometimes also used in engineering and archaeological studies.

Newton's Law of gravitational attraction forms the basis of gravity studies in which the gravity force is expressed in the equation:

$$F = \frac{G m^1 m^2}{d^2}$$

Where:

**F** = Gravitational Force

**D** = Distance between the point masses, m1 and m2

**G** = Gravitational constant which is experimentally determined

### **Magnetic Methods**

Aeromagnetic survey is an economical method used usually for relatively unexplored regions by providing data on broad scale structural trends, the position of faults, basement and volcanic rock distributions within sedimentary basins.

Such magnetic surveys provide invaluable information that is used in planning for costly surface seismic surveys. Moreover, magnetic survey results can be integrated with surface seismic data results by interpreting magnetic profiles surveyed along actual seismic lines.

Basic principle of magnetic surveying is that rocks of igneous origin are naturally highly magnetized than any other rock types. These bodies of magnetized rock produce magnetic field which is apparent as a local anomaly from the earth's total magnetic field.

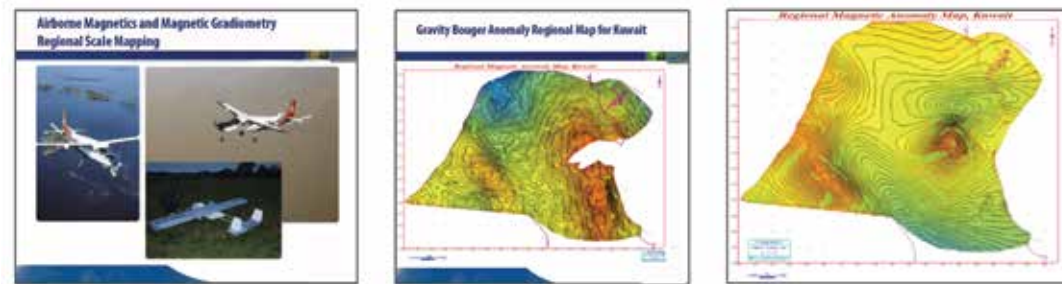

Magnetic surveys are aiming at detecting anomalous magnetic field variations associated with magnetic anomalies and geological structure by comparing the measured magnetic field values with the normal (total reference) earth magnetic field. Thus, a map showing contoured values of the differences between magnetic field measurements and the reference field values is called “Magnetic Anomaly Map”.

### Seismic Methods

The seismic method is the most important geophysical technique in terms of expenditures and number of geophysicists involved. Its predominance is due to high accuracy, high resolution, and great penetration. The widespread use of seismic methods is principally in exploring for petroleum. The locations for exploratory wells rarely are made without seismic information.

Exploration seismic methods involve basically the same type of measurements as earthquake seismology. However, the energy sources are controlled and movable, and the distances between the source and the recording points are relatively small. Much seismic work consists of continuous coverage, where the response of successive portions of earth is sampled along lines of profile.

Explosives and other energy sources such as vibrator trucks are used to generate the seismic waves, and arrays of geophones are used to detect the resulting motion of the earth. The data usually are recorded digitally on magnetic tape so that computer processing can be used to enhance the signals with respect to the noise, extract the significant information, and display it for geological interpretation.

The basic technique of seismic exploration consists of generating seismic waves and measuring the time required for the waves to travel from the sources to a series of geophones. From a knowledge of travel-times and the velocity of the waves, one attempts to reconstruct the paths of the seismic waves.



Structural information is derived principally from paths that fall into two main categories:

Head-wave or refracted paths, in which the principal portion of the path is along the interface between two rock layers and hence is approximately horizontal, and reflected paths, in which the wave travels downward initially and at some point is reflected back to the surface, the overall path being essentially vertical. For both types of path, the travel-times depend on the physical properties of the rocks and the attitudes of the beds.

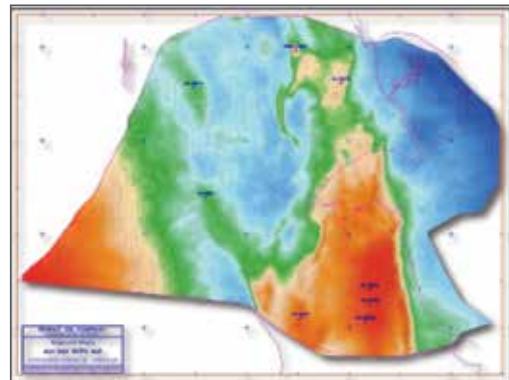

The objective of seismic exploration is to deduce information about the rocks, especially about the attitudes of the beds, from the observed arrival times and (to a lesser extent) from variations in amplitude, frequency, phase, and wave shape.

Despite the indirectness of the method – most seismic work results in the mapping of geological structure rather than finding petroleum directly – the likelihood of a successful venture is improved more than enough to pay for the seismic work. Likewise, engineering surveys, mapping of water resources and other studies requiring accurate knowledge of subsurface structure derive valuable information from seismic data.



## Electrical Methods

Electrical prospecting involves the detection of surface effects produced by electric current flow in the ground. There is a much greater variety of techniques available than in the other prospecting methods, where one makes use of a single field of force or anomalous property - gravity, magnetism, elasticity, radioactivity.

Using electrical methods, one may measure potentials, currents, and electromagnetic fields that occur naturally or are introduced artificially in the earth. Furthermore the measurements can be made in a variety of ways to determine a variety of results. Basically, however, it is the enormous variation in electrical conductivity found in different rocks and minerals that makes these techniques possible.

Electrical methods include self-potential (SP), telluric currents and magnetotellurics (MT), resistivity, including mise-a-la-masse, electromagnetic (EM), including AFMAG, and induced polarization (IP). They are often classified by the type of energy source involved, that is, natural or artificial. On this basis the first three and AFMAG above are grouped under natural sources and the remainder as artificial. Such a classification can be made for prospecting methods in general. Hence, gravity, magnetics, and radioactivity are included in the natural source methods, whereas seismic requires artificial energy.

In the following chapters, we shall study the electrical methods in a slightly different sequence, grouping three natural source methods together but considering AFMAG with EM, because the field techniques are quite similar. For the same reason IP will be considered immediately after resistivity.

## Electromagnetic Methods

Electromagnetic methods are used to map the spatial variation of the Earth's resistivity by measuring naturally occurring electric and magnetic fields at the Earth's surface. These natural EM fields are generated (at all frequencies) in the Earth's atmosphere mainly by lightning strokes and by interactions between the solar wind and the

### Ground Penetrating Radar (GPR) - Method

- Radar (electromagnetic) pulses 10 MHz to 1GHz
- High resolution imaging of very-near surface
- Similar to reflection seismology
- Depth of penetration depends on conductivity of the ground
  - sandy soils, limestone, granite, concrete: ~15 m
  - moist soils, clay laden soils: a few centimeters
- Applications:
  - study of bedrock, soils, groundwater, ice
  - testing of structures and pavements
  - locating buried structures and utility lines
  - define landfills, contaminant plumes
  - archaeological mapping



ionosphere. In the most general MT method, the horizontal components of the electric field and all three components of the magnetic field are measured at the surface. The measurements are used to determine specific ratios of electric to magnetic field components called tensor impedances.

The technique was introduced by the French geophysicist Louis Cagniard in the 1950s and has been popular for mineral exploration and regional geophysical mapping.

These methods are used in oil exploration for low-cost reconnaissance of sedimentary basins and for exploration in areas where seismic surveys are difficult because of severe topography or the presence high-impedance volcanic rocks near the surface.

The resolution of MT surveys is limited by the diffusive nature of EM propagation in the earth; it is usually on the order of hundreds of meters to kilometers, but the MT method can probe the Earth to depths of several tens of kilometers.

### Downhole measurements (Vertical seismic profiling)

The idea of lowering a geophone down a well bore to get a better handle on rock velocity is hardly a new concept. Geophysicists have engaged in the practice with increasing precision since the 1930s - around the time when the first geophones were designed to withstand the rigors of the borehole.

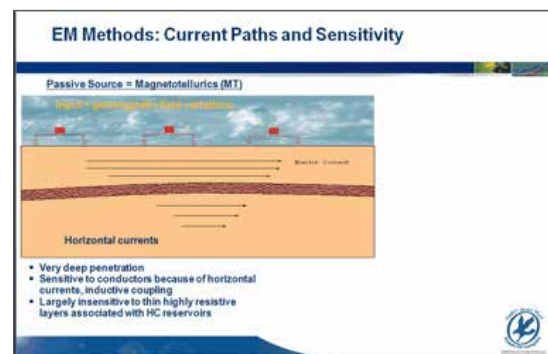

The VSP is simply a precision level step change up from the check shot velocity survey. The basic difference between the check shot survey and the VSP is that the VSP measures nearly all seismic waveforms in the well bore (up-going and down-going energy), whereas the check shot velocity survey measures basically only the down-going energy (Figure below).

Note that a VSP is also a check shot velocity survey but a check shot velocity survey is not a VSP!

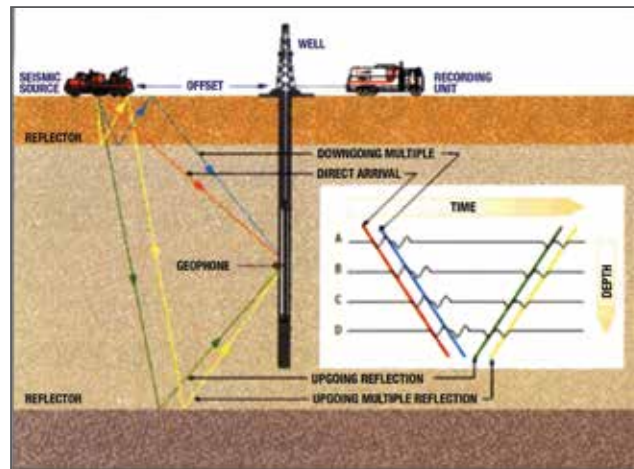

## References

Applied Geophysics (2nd Edition)

By: Telford, W.M.; Geldart, L.P.;  
Sheriff, R.E. © 1990 Cambridge  
University Press.

Senti, R. J. 1988. Geophysical activity  
in 1987. Geophysics, The Leading  
Edge of Exploration I, No. 8, 33-56.

Adel El-Emam 2016. Leading the  
trend—Two decades of evolving  
Geophysics solutions in Kuwait. SEG  
Dallas.



## 5. The Journey of Oil

The journey of oil production (Fig. 5.1, Oil Cycle) starts with a land survey of formation and geological studies to determine the possibilities of finding hydrocarbons in these formations. Once the studies are completed and reveal that hydrocarbons do exist in these formations, exploration operation starts to drill and find out the parameters of the field and the formation.

Drilling operations are always based on drilling programs designed to optimize cost and time. Well planning and well design comes next. They are prepared based on many parameters and many studies. Location preparation is also an important stage of the pre-drilling operations.

The rig moves to the drilling site and the rig goes through a checklist to ensure the readiness of the rig. The crew conducts pre-spud meetings to discuss the roles and responsibilities of the employees and discuss all the related operations issues. Also, in the pre-spud meeting the rig crew discusses the HSE aspect of the operations. Drilling operations drill different sections of the formation and reach the total depth to the pay zone.

The drilling operations drill different sections of formation and reach the total depth to the pay zone.

Once the drilling casing & cementing completed, the pay zone is perforated. The well is tested and completed for production. The well production is hooked to an oil facility called a gathering center, where crude oil is treated to remove solid and water impurities (salts). Crude oil is then transferred to oil tank farms to store the crude oil.

The crude oil then transferred from the oil tank farm to either the refinery for further separation or to exportation. Exportation can be through sea by oil tankers or by land through pipelines. Once the well is depleted and reached an uneconomical limit, then it is abandoned.

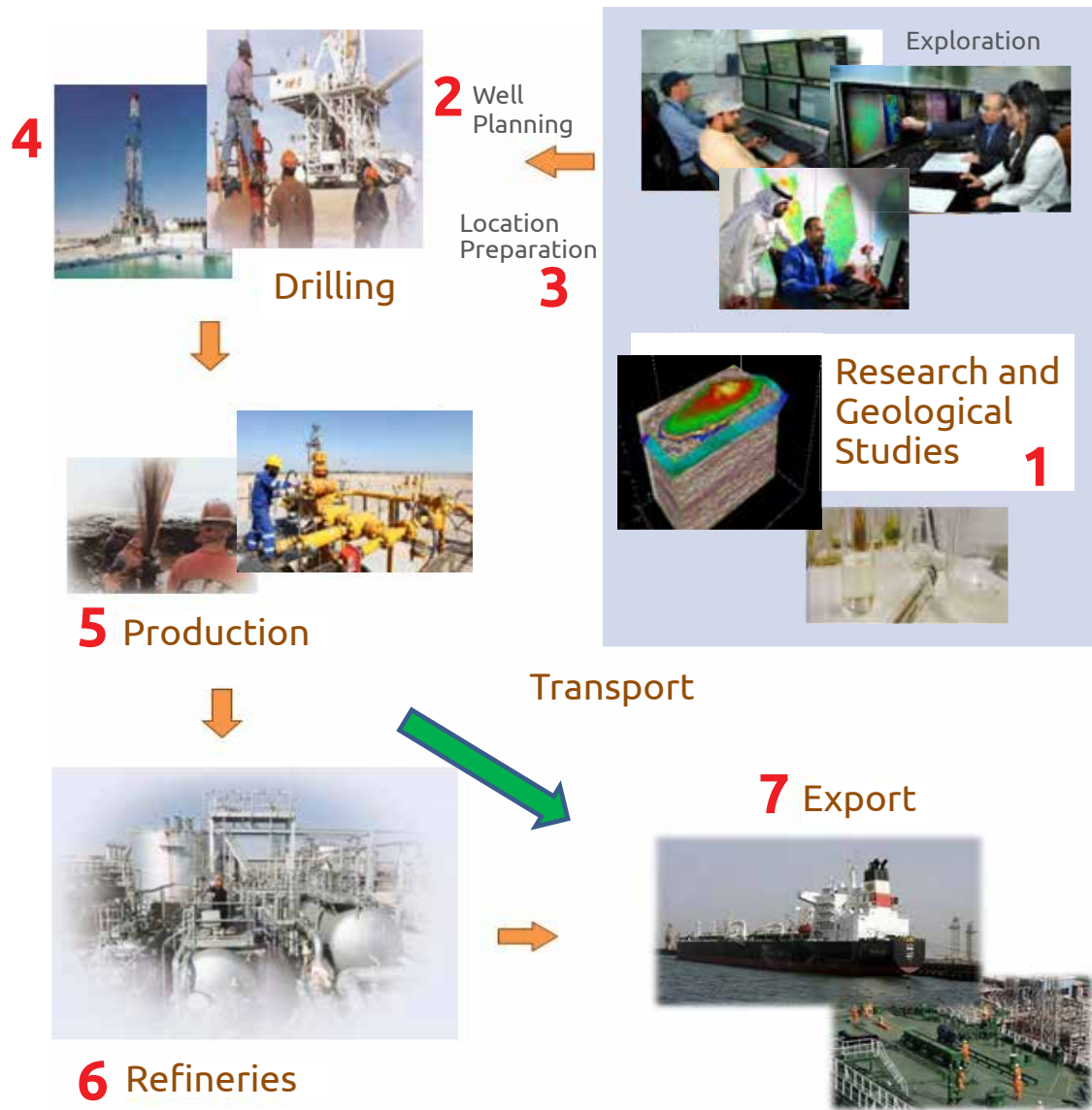

Fig 5.1 – Oil Cycle



## 6. Well Planning

Well planning is the key for successful well drilling operations and being able to do it in a safe, environmentally friendly and economical way as possible.

Planning requires integration between engineering principles, strategies and experience.

Planning starts with estimating the value of the hydrocarbons reserve versus the estimating cost to drill the well and obtain the hydrocarbons. Successful planning requires good data acquisition and a clear objective. Planning also requires sensible decision making and anticipating drilling problems likely to be encountered and possible solutions.

The objective of well planning is to formulate a program from many variables for drilling a well that has the following characteristics:

- Safe
- Minimum cost
- Useable
- Suitable
- Profitable

The plan should take into consideration all significant engineering parameters, events, legal aspects and any factor that might impact the well drilling plan, directly or indirectly.

The well plan process can be classified as follows:

1. Defining the well objective.
2. Obtain the right to drill from authorities.
3. Data acquisition.
4. Identify the pore pressure and formation fracture gradients.
5. Drilling program preparation.
6. Cost estimation and budget preparation.
7. Obtain permits, contracts, licenses and documentations.



A good drilling program is essential for safe and effective drilling operations. The drilling program should be based on thorough data acquisition and analysis of such data while taking into consideration the safety of the workers, the environment and the cost of the drilling.

**The drilling program should consist of the following:**

- Well details
- Well objective
- Depth selection
- Casing design
- Bottom Hole Assembly selection
- Wellhead selection
- Well control requirements
- Cementing program
- Mud program
- Logging & evaluation program
- Deviation program
- Surveys requirements
- Bit Program
- Hydraulics program
- Operation procedures
- Site plan
- Well cost estimation
- Completion plan
- Reporting guidance
- Contacts

**Planning to drill a well consists of three main aspects:**

- Operations, Engineering & Technical Aspect
- Business Aspect
- Administrative Aspect



Fig 7.1 – Land Drilling rig

## Operations, Engineering & Technical Aspect

The Operation, Engineering & Technical aspects consist of the following:

- Enhance the operations with the best possible tools and technologies.
- Perform technical research and advance studies/ testing.
- Share the knowledge within similar oil companies all around the world.
- Ensure the safety of the workers by enhancing the health, safety and environment in the Company.

## Business Aspect

The Business aspects involve the following:

- Evaluating the cost verses profit ratio / Return on Investment (ROI)
- Perform business studies and market value analysis.
- Business enhancement and development

## Administrative Aspect

The administrative aspects involve the following:

- Legal authorization to drill
- Employee training
- Budget - cost optimization and evaluations
- Drilling wells planning
- Workover wells & maintenance planning
- Enhance the company image.
- Perform quality assurance check and quality certifications.
- Contract and services agreement.



# 7. Pre-Drilling Operations

## Location Preparations

Location preparation can only start after marking the target area for drilling, setting up the coordinates, and obtaining the necessary legal steps such as permits to drill the area.

The location is prepared by clearing and leveling the designated drilling area and access roads should be built. (Fig. 8.1)



Fig 8.1 – Location Preparation

## Water source Preparations

Drilling operations requires water on location to serve the drilling operations in many aspects and processes such as drilling, circulation, mixing mud, mixing cement and other activities.

If there is no natural water source nearby then a well must be drilled to ensure a sufficient amount of water for the drilling operations. Building a water lagoon is to be considered in this case.

## Reserve Pit Preparations

A reserve pit must be dug on location to serve as a disposal area for rock cuttings and drilling mud.+



The reserve pit must have a plastic liner to protect the environment. The waste mud is stored until final disposal.

## Cellar Preparations

A rectangular or circular pit, called a cellar (Fig. 8.2), is dug around the location of the actual drilling hole. The cellar provides a workspace around the hole for the workers and drilling accessories.



Fig 8.2 – Cellar Preparation

## Logistics Preparations

Logistics preparations are required prior to the commencement of drilling operations such as the rig tubular, chemical additives, etc.

## Rig Move & Rig up

Move rig on to designated location; the rig and other facilities are set up according to the approved rig layout design. Set up the electricity and water infrastructure on the rig site. (Fig. 8.3)



Fig 8.3 – Land Drilling Rig

## Pre Drilling Rig Inspection & Checklist

The rig is inspected to make sure it is safe and functional before starting operations. The rig crews go through a checklist to make sure everything is set up according to the rig layout in a proper manner.



# 8. Drilling Operations

Once the research and geological studies and the pre-drilling/location preparation is completed, the drilling operations come next. Drilling operation is one of the world's most high-risk businesses.

Drilling operations are conducted in a harsh environment and they are rough by nature due to the constant use of heavy equipment and other dangerous factors such as sharp edges, height, high pressure, dangerous chemicals and many other hazards. The various phases for the development of a field are shown in following chronological basis.

- Exploration
- Evaluation
- Development
- Production/Depletion
- Abandonment

There are two types of well Exploration and Development. A "Workover" rig is also used for well maintenance operations.

## Exploration Well

An exploration well is a well that is drilled in a new area with no previous drilling experience and record for the area to be drilled, where many parameters are unknown such as rock type, rock thickness, formation pressure, type of fluids and other factors.

In the exploration process, the main purpose is to drill a well to identify the physical map of the subsurface structure which will be likely to act as a trap for hydrocarbons in moving from source to the reservoir rock. It is process of find new reserves and successfully find new reservoirs.

Exploratory wells are called "wildcats" and are referred to as "chasing the unknown" in remote graphical areas.

Successful wildcats occur when an oil discovery happens. Unsuccessful wildcats occur when no oil is found. This is called a dry hole.

Globally, the approximate ratio is for every four dry wildcats there is only one successful wildcat well.

## Evaluation

Drilling exploratory wells provide important information such as the following:

1. Well cuttings/rock fragments that result from drilling a well are carried to



the surface by the drilling fluid and then screened out of the liquid mud system by a device called a “Shale Shaker.” Well cuttings are monitored for composition, size, shape, color, texture, hydrocarbons content and other properties by the mud engineer, mud logger and other personnel.

2. Core sampling is a cylindrical section of vertical sequences of the rock layers taken from a well to evaluate the rock properties and to obtain information that the well cutting could not provide. Core analysis is carried out to obtain important information such as porosity, permeability, type of oil-bearing rocks and hydrocarbon saturation. The information can also determine the oil reserves.
3. Drilling fluids used in the drilling operations are affected by the type of rock and the fluids in the formation such as oil, water and gas. For this reason, a good analysis of the drilling fluids can provide important information for drilling operations such as viscosity, density, temperature, salinity and presence of traces of hydrocarbon components.
4. Well logging is used to determine the rock type by performing measurements to know the rock properties such as rock density, electrical resistance, natural radiation and temperature. The common logs are used to evaluate the reservoir such as driller’s logs, mud logs, sample logs, multiple logs (caliper, density, velocity, porosity), core logs, and wire line logs.
5. Well Testing provides information on the presence of hydrocarbons, the production capacity of the well and the relationship between reservoir pressure and the production rate. All these measurements are to identify if there is a commercial quantity of hydrocarbons or not.

After the successful exploratory oil discovery, delineation wells are drilled along what the engineers believe to be the outer perimeter of the reservoir.

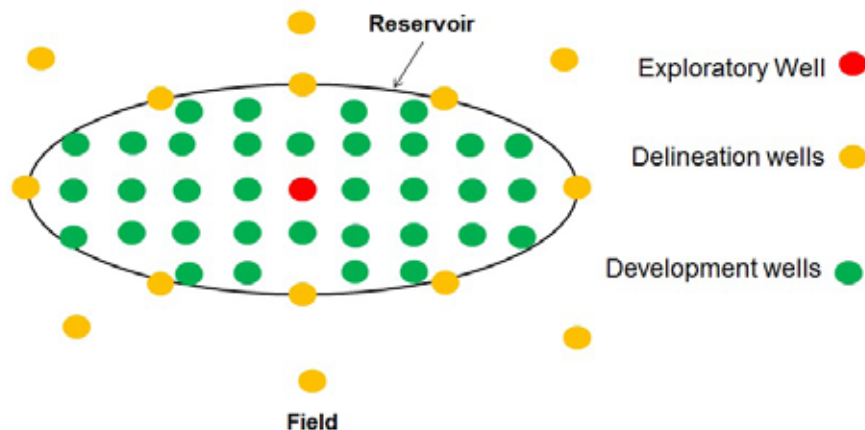

Fig 9.1 – Well Types



If the delineation well is drilled in a proven area then it is considered a development well. However, if the delineation well is drilled in an unproven area then it is considered an exploratory well.

If there are hydrocarbons in commercial quantities, then it is a successful operation. When new hydrocarbon reservoirs are discovered, it is called a productive well. If the testing reveals that the hydrocarbons are not in commercial quantities, it is called dry well.

## **Development Well**

Once the information has been gained from the exploration and evaluation phases and the reservoir has been modelled to identify the amount of hydrocarbons which can be recovered, the reservoir development will be designed and the economics evaluated.

The development well's main target is to drill a well to further develop the field by increasing the recovery and production.

## **Workover Well**

A workover well is when the well is having problems and needs to be repaired to restore the well productivity to reach optimum production.

## **Requirement to drill a well**

These are requirements to drill which include the rig, drill bit, mud, material, casing, cement, logging (open hole and cased hole).

## **Types of drilling wells**

### **Producer**

Producer wells are drilled primarily for producing oil or gas once the producing structure and characteristics are determined.

### **Injector**

Water injector wells inject water into the formation to maintain reservoir pressure. Water injection into the producing zone frequently has an element of reservoir management; however, produced water disposal is often into shallower zones that are safely beneath any fresh water zones.



## Disposal

Disposal wells are used simply to dispose of water produced with the hydrocarbons because even after treatment, it would be too oily and too saline to be considered clean for dumping into the environment because it may harm the environment and pollute the fresh water zones.



Fig 9.2 – Land Drilling Rig

## Abandonment

The performance of individual wells will be continually monitored and periodically assessed to identify ways in which their performance could be improved and their production made more economic. At some stage in the production of the well, a point will be reached whereby the well can no longer produce oil or gas economically i.e., the cost of the well and its production will exceed the revenue arising from fluid production.



Fig 9.3 –Drilling Rig Crew



## Rotary Drilling

A rotary drilling rig is a combination of many machines and equipment that are integrated with each other to drill a hole in the ground. The machinery and equipment define five main systems on a drilling rig:

- The power system
- The hoisting system
- The circulating system
- The rotary system
- The well control system

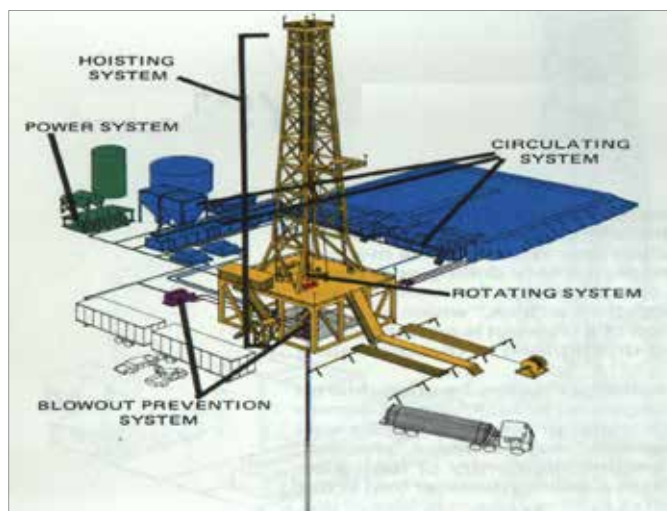

Fig 9.4 – Rig Systems

Source: <http://dickalive.blogspot.com>

## The Power System

In order for the rig to operate, the rig needs a source of power to run the hoisting, circulating, and rotating equipment. In the early days of drilling up to 1940, steam engines were used to generate power for the rig. Internal combustion engines are now used to generate power by using diesel or liquefied petroleum gas.



The common means of transmitting power from the prime mover to the rig components are:

1. Mechanical
2. Electrical

On mechanical drilling rigs, also called power rigs, the rotary energy of the diesel engines is transferred directly to the draw works, mud pumps, and rotary table via a system of chains (chain drive) or belts (belt drive), torque converters and clutches.



Fig 9.5 – Rig power engines

In addition, a separate generator set produces electricity to power the lighting system of the rig as well as small AC motors used by equipment of the mud control system.

On an AC powered rig, AC generator sets (diesel engine plus AC generator) produce alternating current that is operated at variable speed via a variable-frequency drive (VFD).



Fig 9.6 –SCR

Source: <http://www.drillingstructuresintl.com>

### AC versus DC Drilling Rig

Apart from being more energy efficient, AC powered rigs allow the drilling operator to more accurately control the rig equipment, thus enhancing rig safety and reducing drilling time.

Diesel internal-combustion engines generate the power. Power generated ranges from 1000 to 3000 Horse Power. These engines supply power for the entire rig package, including but not limited to draw works, mud pumps and other auxiliaries of the rig including the lighting.

Today, SCR (silicon-controlled rectification) rigs are the most common, where the rig uses efficient A/C-DC electric current to run most of its equipment. Most large rigs use the SCR power option. (Fig. 9.6)

The generator on a rig generates alternating current AC power and then transfers it to the SCR room (Silicon Control Rectifier) to convert the power to direct current DC. The DC power gives better control of speed of the equipment. (Fig. 9.7)

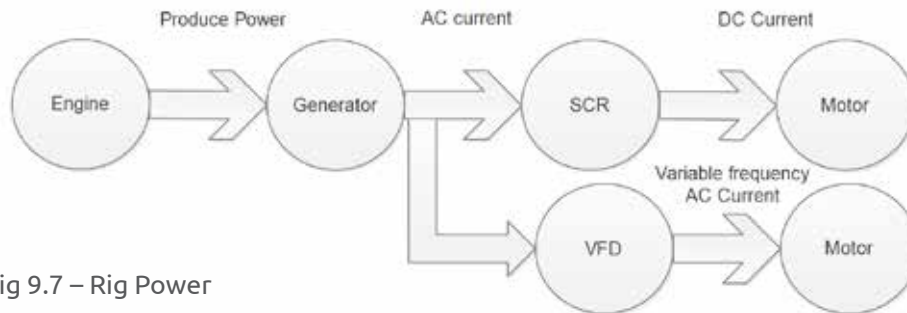

Fig 9.7 – Rig Power Cycle

Table (A) shows the comparison between electrical and mechanical power systems.

Power System	Safety	Cost	Noise	Rig Space
Mechanical	High	Low	Low	Low
Electrical	Low	High	High	High

Table (A) - comparison between electrical and mechanical power systems

## The Hoisting System

The rig needs a hoisting system to raise and lower the drill string in and out of the hole. It is also used to hold the bottom hole assembly (BHA) i.e. drill pipe in place. (Fig. 9.8)

The hoisting system consists of:

- Mast or Derrick
- Traveling and Crown Blocks
- Drilling line
- Draw works

### Mast or Derrick

- To provide vertical height for pipe movement
- To allow enough vertical space to install the blow out preventer (BOP).



## Crown & Traveling Block

- To provide mechanical advantage on weight distribution.

## Drawworks

To provide necessary pull for raising the drill string.

Power rating of the draw works having practical rule of the thumb for it: every 100 feet of borehole requires 10 horsepower at the draw works. For the rig categories listed above, this gives:

- Lightweight rigs 650 hp
- Intermediate rigs 1300 hp
- Heavyweight rigs 2000 hp
- Ultraheavy rigs 3000 hp

### There are two types of Brakes:

1. Main Brake
  - Hydro-matic or Hydraulic Brake
  - Elmago Brake or Electro-Magnetic Brake

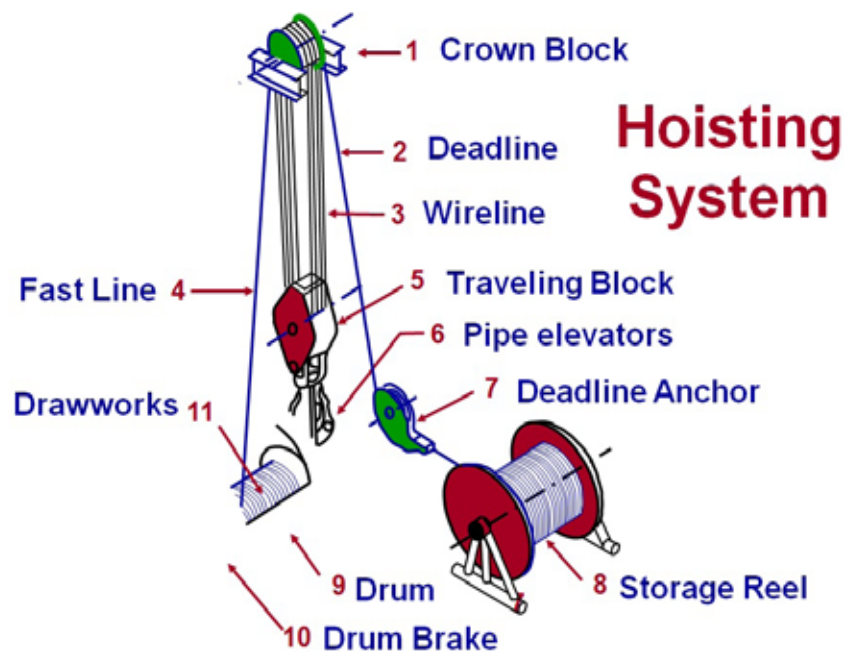

Fig 9.8 – Rig Hoisting System



## The Circulation System

The circulation system moves drilling fluids inside the drill string to the bottom of the drill string, out of the bit nozzles and then comes back to the surface equipment through the mud return line into the shale shaker screen where the solids are separated and the mud and fine particles fall through the screen into the first mud tank. The mud goes through several gas removal equipment such as the degasser and solid removal equipment such as the desander and desilter.

Then the solid free mud enters the suction tank and gets treated with the necessary chemicals to enhance certain mud properties such as Barite (increase weight of mud), clay or other chemicals.

### Objective:

- To circulate cuttings out of the hole.
- To control the reservoir pressure.
- Protect the hole from collapse and flow.
- Lubricate the bit.
- Protect the drill string from corrosion.

## Drilling Fluid

Drilling fluid is a mixture of chemicals in a major solvent i.e. water or oil, and the slurry is usually called drilling mud. Circulating fluid can be air or gas as well.

## Mud Tanks and Mud Pumps

The mud is mixed in large tanks called mud tanks or mud pits through the equipment called Mixing Hoppers. Mostly dry ingredients are injected through the hoppers and water or oil is poured into the tanks through pipes attached to the vessels.

Drilling fluid is designed with special viscosity, mud properties and weight according to the chemical and physical conditions of the borehole.

## Mud Pumps

Mud pumps are electrically/diesel-powered and are capable of moving large volumes of fluids into the hole with the desired pressure. Mud pumps are



considered the heart of the circulating system, and they must be powerful because they must be able to pump at a high pressure and carry heavy and thick mud.

There are two types of mud pumps commonly used in drilling operations:

1. Duplex: This contains two cylinders for pumping the mud.
2. Triplex: This contains three cylinders for pumping the mud.

Table (B) shows the comparison between Triplex and Duplex mud pumps.

Mud Pump Type	Efficiency	Weight	Pulsation Pressure	Discharge Pressure	Maintenance Time	Cost
Triplex	High	Light	Low	High	Short	Low
Duplex	Low	Heavy	High	Low	Long	High

Table (B): comparison between triplex and duplex mud pumps.

## The Mud Cycle (fig. 9.9)

The mud cycle is a closed system where the drilling fluid passes through equipment that is on the surface and sub-surface.

The cycle functions according to the following:

- Mud tank/mud pits.
- Pumps.
- Stand pipe and Kelly hose/mud hose.
- Swivel and Kelly/Top drive.
- Drill string (Inside downward flow).
- Bit (Through the nozzles).
- Annulus (Space between drill pipe and wellbore wall, upward flow).
- Mud return line/flow Line.
- Shale shaker, desander, desilter and other solid control equipment.
- Back to mud tanks

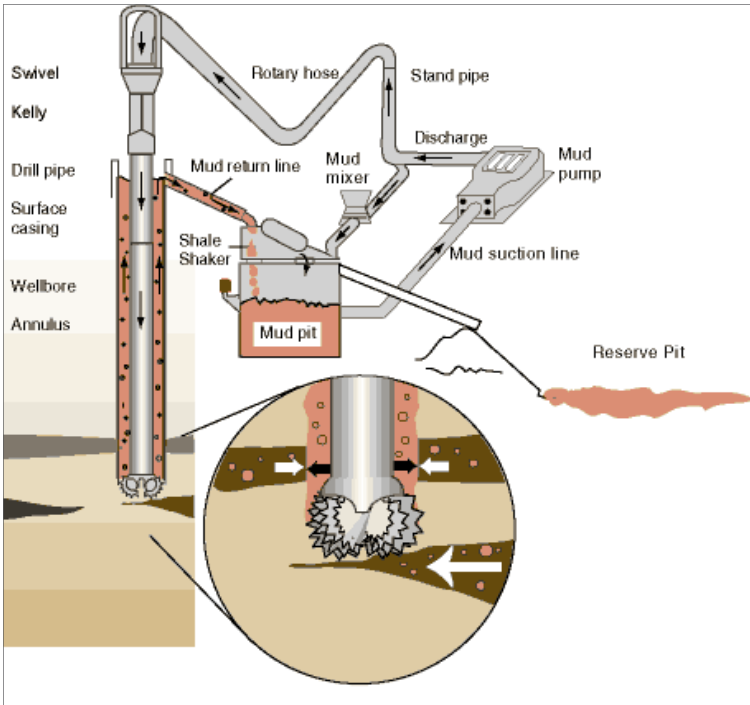

Fig 9.9 – Mud Cycle  
Source: <http://www.osha.gov>

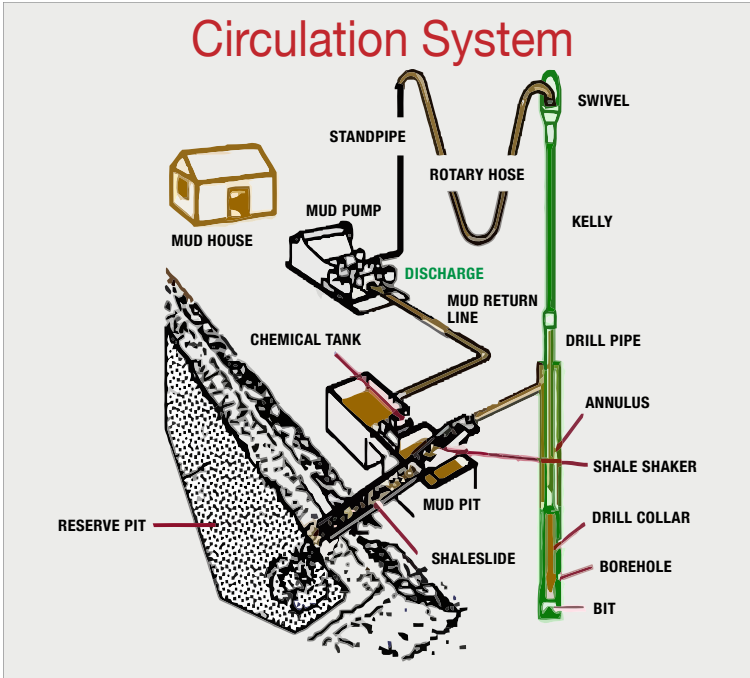

Fig 9.10 – Rig Circulation System  
Source: <http://www.spescusc.org>



## Rotating Systems

Rotating systems consist of the components that turn the drill bit to dig the hole deeper into the ground. There are three types of rotary equipment: These include a rotary table and Kelly system, top drive system, and downhole motor that can be used with or without the rotary table or top drive. (Fig. 9.11)

The drill string consists of many different tools that have their own function and characteristics. The most common drill string consists of a drill pipe and drill collar (Fig. 9.12). The upper side of each pipe is called a box side and the lower side is called a pin side.

Normally, each joint of pipe is about 30 ft. in length, and when they are joined in three they are called a stand.

### Drill string equipment:

- Drill Pipe (S, G, D, E grades of drill pipes)
- Drilling Jar
- Logging string
- Drilling jar
- Heavy weight drill pipe (HWDP)
- Drill collars (DC) – steel / monel (Non-magnetic)
- Reamer
- Stabilizer
- Crossovers
- Mud motor / Direction drilling motor
- Bits

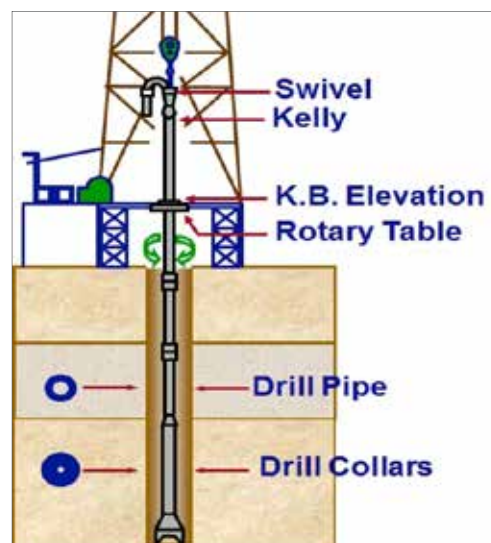

Fig 9.11- Rotating System



Drill collars are much thicker than drill pipes. Drill collars add weight to the drill string to add weight on the bit for better drilling penetration rates.



Figure 9.12 – Drill Collar

Source:[http://www.diytrade.com/china/4/products/4185014/drill\\_collar\\_API.html](http://www.diytrade.com/china/4/products/4185014/drill_collar_API.html)

## Drilling Bits

The drilling bit is located at the bottom of the drilling stem. The drilling bit is rotating cutting equipment that cuts the formation and penetrates a hole into the ground (Fig. 9.13). The drilling bit selection is based on the hardness of the formation to be drilled. The rate of penetration (ROP) is one of the measures used to identify the bit performance. ROP increases in fast drilling formations such as sandstone and decreases in slow drilling formations such as shale. It is normally measured in feet per minute.

There are several types but the most common types are the roller cone and the drag bits. The drilling bits come in different sizes to be able to drill different sizes of holes.

The roller cone has either steel teeth or tungsten carbide inserts (Fig. 9.14.1). The roller cone bits usually consist of three cone-shaped steel parts that can rotate. The roller cone bits can also come in two or four cone-shaped steel parts. The roller cone crushes the formation when the teeth of the roller contacts the formation.



The drag bits or the diamond bits consist of steel blades, natural diamond, or synthetic polycrystalline diamond compact (PDC) (Fig. 9.14.2).

The diamond bits have small industrial diamond cutters instead of roller cones. The mud circulation is very important to cool the drilling bit and prevent it from getting damaged.

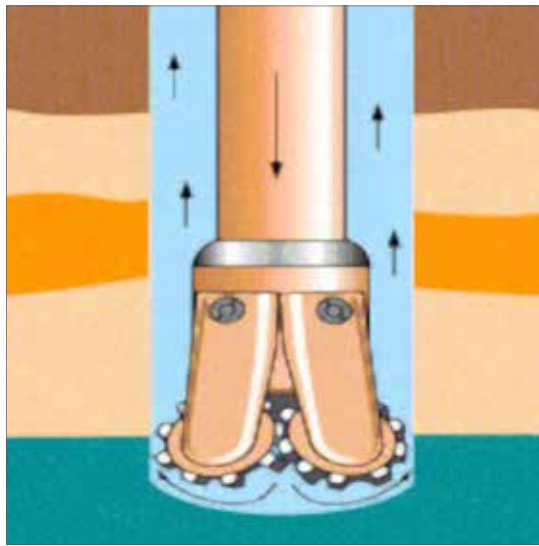

Figure 9.13 - Drilling Bit

Source: <http://wintermud.com/how.html>



Fig. 9.14.2 - Diamond bits

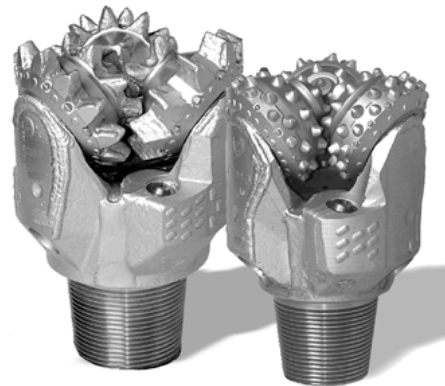

Fig. 9.14.1 - Roller Cone bits



# Top Drive System

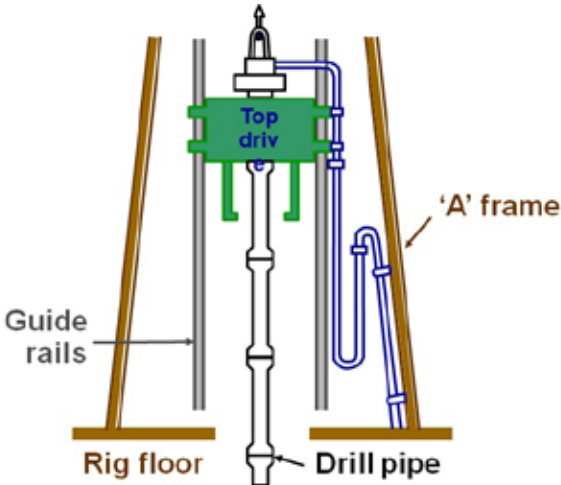

Fig 9.15- Top Drive System



Fig 9.16- Top Drive System

Sources: <http://drillingclub.proboards.com>



## Well control system

The well control system consists of many components to control the well and prevent blow outs. The well control system maintains the fluid column hydrostatic pressure and the formation pressure to prevent a kick, which is an influx of formation fluid into the wellbore. The equipment used for well control systems is BOP (Blow Out Preventers) (Fig. 9.17); Choke Manifold; kill manifold; Trip Tank and Flare line/pit.

Objective:

- To detect a kick.
- To shut in the well when a kick is taken.
- To control well pressure.
- To prevent surface blow out.
- To save the drilling crew from potential death.

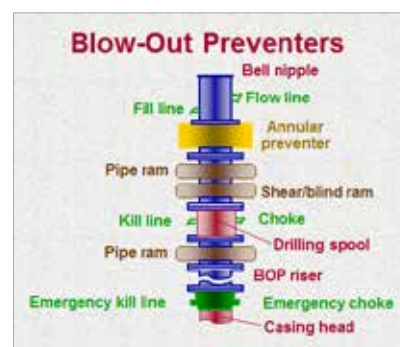

Fig 9.17- Blow Out Preventers



There are two lines of defense to control the well: primary well control and secondary well controls.

## Primary Well Control

The primary well control, which is the mud, is the first line of defense. The mud maintains the well's hydrostatic pressure. (Fig. 9.18) If hydrostatic pressure is less than formation pressure then formation fluids will enter the wellbore. If the hydrostatic pressure of the fluid in the wellbore exceeds the fracture pressure of the formation then the fluid in the well could be lost. (Fig. 9.19)

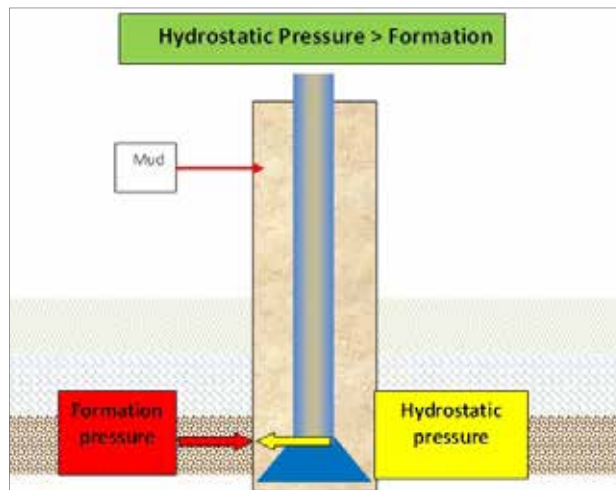

Fig 9.18

Mud is the primary defense line as it maintains a hydrostatic pressure.

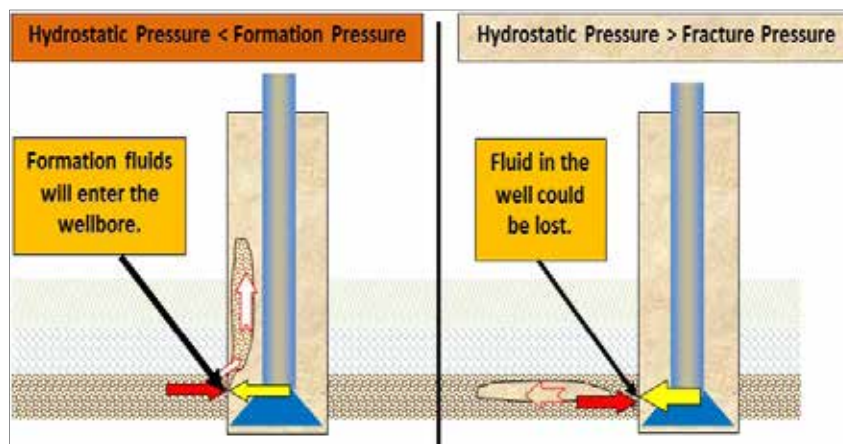

Fig 9.19 The relationship between hydrostatic pressure and formation pressure.



## Secondary Well Control

This is the second line of defense. If the pressure of the fluids in the wellbore fails to prevent formation fluids entering the wellbore, then the well will flow. This can be prevented by using the Blow Out Preventer to prevent the escape of wellbore fluids from the well (Fig. 9.20).

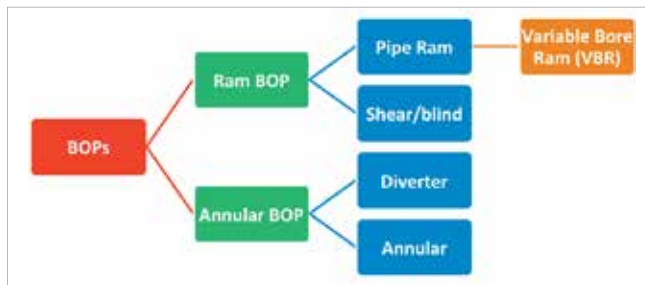

Figure 9.20- Secondary Well Control

## Kick or Blowout

When the formation fluids or gas enters into the wellbore hole and it cannot be controlled by the drilling mud, then it is called “kick.” If it is out of control it is called a “blow out.”

The rig must have equipment to detect kick such as a flow indicator, pit level indicator and trip tank.

## Blow out Preventers (BOP)

This equipment is used to close the well and to divert the Kicked fluids towards the choke manifold and flare line. (Fig. 9.21)

There are of two types of blow out preventers:

- Annular Preventer
- Ram Preventer



Fig 9.21 Blowout preventers

Sources: <http://www.osha.gov>



## Accumulators

BOPs are opened or closed by hydraulic fluids kept under pressure in a device called an accumulator. (Fig. 9.22)

Hydraulic fluids are kept under pressure about 1500 - 3000 psi with the help of nitrogen gas. The accumulator is usually placed about 100 feet away from rig floor.



Fig 9.22 Accumulator

## Choke Manifolds

This equipment is used to circulate the kick or divert the excess fluid to the flare line or to the shaker tank through the mud gas separator. (Fig. 9.23)



Fig 9.23 Choke Manifolds



## Trip tank

Trip tanks are small metal tanks with small a capacity of about 20-40 bbls with 1 bbl divisions inside. They are used to monitor the well. (Fig. 9.24)



Fig 9.24 Trip Tank

Sources: <http://drillingahead.com>

## Auxiliaries

### Electricity Generators

Rigs are provided with AC current diesel-powered generators, which run normally in range from 50 to 100 kilowatts of power for the different operating units for the rig camp instrumentation and lighting.

### Air Compressors

Compressors supply air to numerous pneumatic controlled equipment.

### Mud Storage Facility

A complete mud system requires large volume of mud storage that consist not only of suction tanks but also require reserve tanks for further use.



## Drilling Instruments

A great variety of electronic, pneumatic, and mechanical equipment have sensors, gauges and recorders present in today's rig to monitor and analyze the drilling parameters systematically and accurately.

## Other facilities

Other facilities like fuel storage, living quarters, equipment spare stores, and rig site offices are available to facilitate crew and to enhance the work efficiency on the rig site.

## Drilling Activity

The crew sets up the rig and starts the drilling operations. First, through the conductor casing they drill a surface hole down to a pre-set depth, which is somewhere above where they think the oil trap is located.

There are five basic steps to drilling the surface hole:

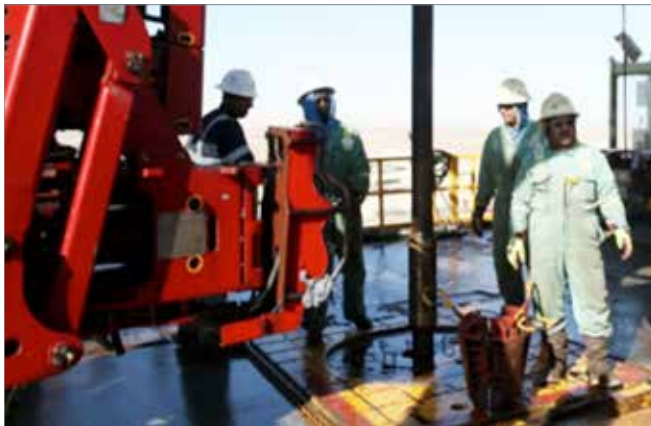

Fig 9.25 Rig crew working on rig floor

1. Place the drill bit, collar and drill pipe in the hole.
2. Attach the Kelly & turntable or top drive and begin drilling.
3. As drilling progresses, circulate mud through the pipe and out of the bit to float the rock cuttings out of the hole.
4. Add new sections (joints) of drill pipes as the hole gets deeper.
5. Remove (trip out) the drill pipe, collar and bit when the pre-set depth (anywhere from a few hundred to a couple thousand feet) is reached.



Once they reach the pre-set depth, sections of steel pipe known as casings which are slightly smaller in diameter than the borehole are placed in the hole and then cement is pumped between the outside of the casing and the borehole. The casing objective is to prevent the hole from collapsing, provide isolation from formation fluids and many more advantages.

The casing pipe has centralizer around the outside to keep it centered in the hole.

After running casing pipe in the hole, the cement is pumped down the casing pipe using a bottom plug, cement slurry, a top plug and drill mud.

The pressure from the drill mud causes the cement slurry to move through the casing and fill the space between the outside of the casing and the hole.

Finally, the cement is allowed to harden and then tested for such properties as hardness, alignment and a proper seal.

Drilling operations continue all over again with drilling another smaller size hole and so on till reach the drilling total depth and reach the pay zone. (Fig. 9.26)

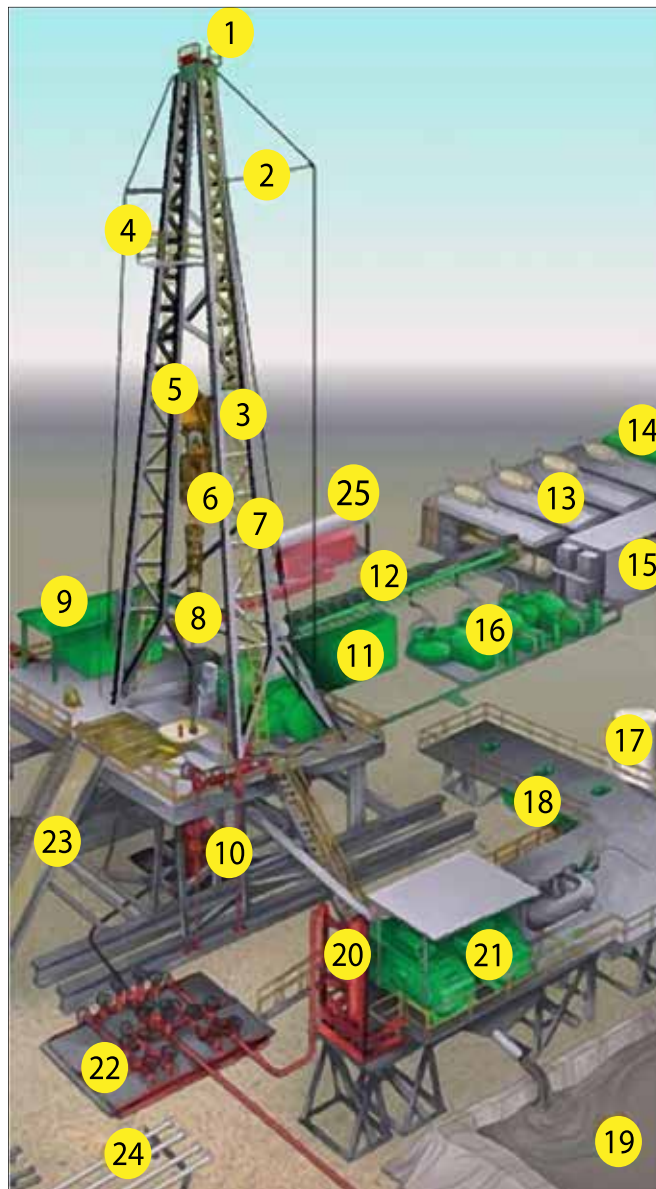

Fig 9.26 Well Drilling Operations Cycle



# 9. Rig Components

The rig consists of many components (Fig. 10.1)



1. CROWN BLOCK AND WATER TABLE
2. CATLINE BOOM AND HOIST LINE
3. DRILLING LINE
4. MONKEY BOARD
5. TRAVELING BLOCK
6. TOP DRIVE
7. MAST
8. DRILL PIPE
9. DOGHOUSE
10. BLOWOUT PREVENTER
11. WATER TANK
12. ELECTRIC CABLE TRAY
13. ENGINE GENERATOR SETS
14. FUEL TANK
15. ELECTRICAL CONTROL HOUSE
16. MUD PUMPS
17. BULK MUD COMPONENT TANKS
18. MUD TANKS (PITS)
19. RESERVE PIT
20. MUD-GAS SEPARATOR
21. SHALE SHAKERS
22. CHOKE MANIFOLD
23. PIPE RAMP
24. PIPE RACKS
25. ACCUMULATOR

Figure 10.1

Source: [http://www.osha.gov/SLTC/etools/oilandgas/illustrated\\_glossary.html](http://www.osha.gov/SLTC/etools/oilandgas/illustrated_glossary.html)



## Mast / Derrick

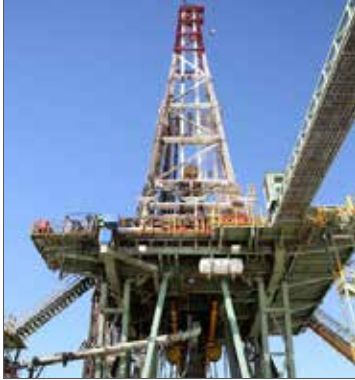

A large load bearing structure, usually bolted construction. The standard mast/derrick has four legs standing at the corner of the substructure. For land transportation, the mast/derrick can be divided into two or more sections.

## Hoist Line / Lifting cylinders



A structural framework/derrick is erected with the help of a hoist line or lifting cylinders.

## Monkey board



The derrick man's working platform. A monkey board is located at a height in the derrick or mast equal to two, three, or four lengths of pipe.



## Crown Block



An assembly of sheaves or pulleys mounted on beams at the top of the derrick. The drilling line is run over the sheaves down to the hoisting drum.

## Traveling Block



An arrangement of pulleys or sheaves through which drilling cable is reeled, which moves up or down in the derrick or mast.

## Hook



A large, hook-shaped device from which the elevator bails or the swivel is suspended. It is designed to carry maximum loads ranging from 100 to 650 tons and turns on bearings in its supporting housing.



## Top Drive



The top drive rotates the drill string end bit without the use of a Kelly and rotary table. The top drive is operated from a control console on the rig floor.

## Drill Pipe



The heavy seamless tubing used to rotate the bit and circulate the drilling fluid. Joints of pipe 30 feet long are coupled together with tool joints.

## Doghouse



A small enclosure on the rig floor used as an office for the driller or as a storehouse for small objects. Also, any small building used as an office or for storage.



### Electric Cable Tray



Supports the heavy electrical cables that feed the power from the control panel to the rig motors.

### Engine Generator Sets



A diesel, Liquefied Petroleum Gas (LPG), natural gas, or gasoline engine, along with a mechanical transmission and generator for producing power for the drilling rig. Newer rigs use electric generators to power electric motors on the other parts of the rig.

### Fuel Tanks



Fuel storage tanks for the power generating system.



## Electric House



On diesel electric rigs, powerful diesel engines drive large electric generators. The generators produce electricity that flows through cables to electric switches and control equipment enclosed in a control cabinet or panel. Electricity is fed to electric motors via the panel.

## Blowout Preventer



A large valve, usually installed above the wellhead, that forms a seal in the annular space between the pipe and wellbore or, if no pipe is present, on the wellbore itself.

## Ram Blowout Preventer



A blowout preventer that uses rams to seal off pressure on a hole that is with or without pipe. It is also called a ram preventer. Ram-type preventers have interchangeable ram blocks to accommodate different O.D. (Outer Diameter) drill pipe, casing, or tubing.



## Accumulator



The storage device for nitrogen pressurized hydraulic fluid, which is used in operating the blowout preventer.

## Diverter



The drilling diverter is a key component used for onshore or offshore drilling operations during surface layer drilling before to use BOPs. The primary function of a diverter is to divert shallow gas through the flare line and avoids shutting in the well, but instead permits routing of the flow to a safe distance on the downwind side of the rig.

## Double Studded Adapter



DSA – The Double Studded Adapter flange is the part which is often used in the wellhead system. The DSA is designed and manufactured in accordance with API 6A standard. DSA usually has double studded flange connections.



## Mud Cross (Drilling Spool)



A mud cross is also known as a drilling spool. It is used as spacers on the BOP stack and provides outlets to attach lines extending to Choke and Kill Manifolds.

## Inside BOP



Installed on the drill string to control formation pressure backflow through the drill pipe during kicks. During normal circulation of drilling fluids down the drill pipe, the valve remains open to permit the flow through it. When any backflow occurs, the valve closes automatically to contain it, protecting the drilling equipment as well as controlling the kick that could otherwise lead to a blowout.

## Fully Open Safety Valve



The Ball-Type Safety Valve is designed to stab into the drill pipe or tubing at the rig floor and close quickly in case a well kicks. After weighting material is added to the mud, the Kelly is reconnected, the valve is opened and circulation can be restored.



## Kill Manifold



As the wellhead pressure increases, the kill manifold can be used to pump heavy drilling fluid into the well, so as to balance the bottom hole pressure and avoid well kick and blowout. The bottom hole pressure can also be released via the relief pipeline connected to kill manifold; The kill manifold can also be used for injecting water and fire extinguishing agent into the well during cement squeeze and well cementing operations. The kill manifold is designed in accordance to API standards.

## Choke Manifold



The arrangement of piping and special valves, called chokes, through which drilling mud is circulated when the blowout preventer are closed to control the pressures encountered during a kick.

## Mud Pump



A large reciprocating pump used to circulate the mud (drilling fluid) on a drilling rig.

## Pulsation Dampeners



Pulsation Dampeners help smooth the flow by counteracting the pulsations that are typical of positive displacement reciprocating pumps such as in mud pumps.



## Bulk Mud Components in Storage



Hopper type tanks for storage of drilling fluid components.

## Mud Pits



A series of open tanks that are usually made of steel plates, through which the drilling mud is cycled to allow sand and sediment to settle out. Additives are mixed with the mud in the pit, and the fluid is temporarily stored there before being pumped back into the well. Mud pit compartments are also called shaker pits, settling pits, and suction pits, depending on their main purpose.

## Water Tank



Used to store water that is used for mud mixing, cementing, and rig cleaning.



## Reserve/Waste Pits



A mud pit in which a supply of drilling fluid has been stored. Also, a waste pit, usually an excavated, earthen-walled pit. It may be lined with plastic to prevent soil contamination.

## Mud Gas Separator / Poor Boy Degasser



A device that removes gas from the mud coming out of a well when a kick is being circulated out.

## Shale Shaker



A series of trays with sieves or screens that vibrate to remove cuttings from circulating fluid in rotary drilling operations. The size of the openings in the sieve is selected to match the size of the solids in the drilling fluid and the anticipated size of cuttings. Also called a shaker.



## Degasser



The equipment used to remove unwanted gas from a liquid, especially from drilling fluid.

## Desander



A centrifugal device for removing sand from drilling fluid to prevent abrasion of the pumps. It may be operated mechanically or by a fast-moving stream of fluid inside a special cone-shaped vessel, in which case it is sometimes called a hydro-cyclone.

## Desilter



A centrifugal device, similar to a Desander, used to remove very fine particles, or silt, from drilling fluid. This keeps the amount of solids in the fluid to the lowest possible level.



## Pipe Ramp



An angled ramp for dragging drill pipe up to the drilling platform or bringing pipe down off the drill platform.

## Catwalk



The ramp at the side of the drilling rig where pipe is laid to be lifted to the derrick floor by the catline or by an air hoist.

## Pipe Racks

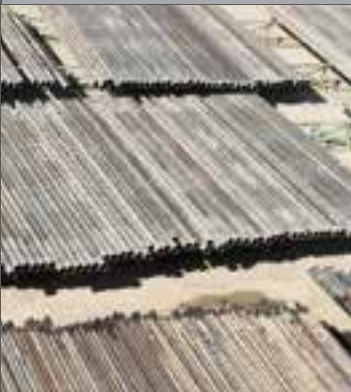

A horizontal support for tubular goods.



## Cellar



A pit in the ground to provide additional height between the rig floor and the wellhead to accommodate the installation of blowout preventers, rat holes, mouse holes, and so forth. It also collects drainage water and other fluids for disposal.

## Conductor Pipe



The largest diameter casing and the topmost length of casing. It is relatively short and encases the topmost string of casing.

## Casing Head



A heavy, flanged steel fitting connected to the first string of casing. It provides housing for slips and packing assemblies, allows suspension of intermediate and production strings of casing, and supplies the means for the annulus to be sealed off. Also called a spool.



## Annulus



The space around a pipe in a well bore, the outer wall of which may be the wall of either the borehole or the casing; sometimes termed the annular space.

## Bell Nipple



An enlarged pipe at the top of the BOP that serves as a funnel to guide drilling tools into the top of a well. The bell nipple is usually fitted with a side outlet to permit drilling fluids to flow back to the surface mud treating equipment through another inclined pipe called a flow line.

## Drawworks



The hoisting mechanism on a drilling rig. It is essentially a large winch that spools off or takes in the drilling line and thus raises or lowers the drill stem and bit.



## Drilling Line



A wire rope hoisting line, reeled on sheaves of the crown block and traveling block (in effect a block and tackle). Its primary purpose is to hoist or lower drill pipe or casing from or into a well. Also, a wire rope used to support the drilling tools.

## Brake



The braking device on the draw works to stop the free fall of suspended load being lifted.

## Electromagnetic Brakes



Electro-magnetic auxiliary brake on side of drawworks which is also known as "Elmago".



## Cathead



A spool-shaped attachment on a winch around which rope for hoisting and pulling is wound.

## Crown-O-Matic Safety Device



The Automatic Crown Safety Device (Crown-O-Matic) is a safety aid installed on a drawworks drum to control the distance a traveling block may be pulled into the derrick, eliminating the possibility of pulling the traveling block into the crown.

## Dead Line Anchor



The dead line is anchored in the substructure.

The anchor is on the spool side.



## Drill Bit



The cutting or boring element used in drilling oil and gas wells. Most bits used in rotary drilling are roller-cone bits.

The bit consists of the cutting elements and the circulating element.

The circulating element permits the passage of drilling fluid and uses the hydraulic force of the fluid stream to improve drilling rates.

## Drill Collar



A heavy, thick-walled tube, usually steel, used between the drill pipe and the bit in the drill stem. It is used to put weight on the bit so that the bit can drill.

## Drillers Console



The control panel, located on the platform, where the driller controls drilling operations.



## Elevators



A set of clamps that grips a stand, or column, of casing, tubing, drill pipe, or sucker rods, so the stand can be raised or lowered into the hole.

## Escape Line (Geronimo)



A steel cable attached to the rig mast near the work platform for the derrick man. This cable is anchored at ground level away from the mast in a loose catenary profile, and fitted with a handle and hand brake that is stored at the top. The escape line provides a rapid escape path for the derrick man should well conditions or massive mechanical failure warrant. The escape line is also known as the "Geronimo line".

## Tugger Winch



A hydraulic / pneumatic mechanized system, where wire rope is used to hoist equipment and personnel up the derrick. Must conform to the API standards for its intended uses.



## Kelly



The heavy square or hexagonal steel member suspended from the swivel through the rotary table. It is connected to the topmost joint of drill pipe to turn the drill stem as the rotary table turns.

## Kelly Bushing



A device fitted to the rotary table through which the Kelly passes. It is the means by which the torque of the rotary table is transmitted to the Kelly and to the drill stem. Also called the drive bushing.

## Kelly Cocks



Kelly Cocks connected to the upper end of the drill pipe and below the Kelly savers, the Kelly Cock is a ball valve used to prevent well blowouts.

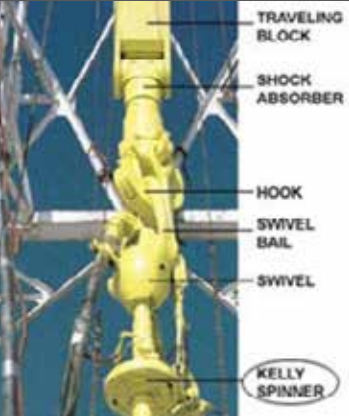

Kelly Spinner	
	<p>A device for spinning the drill pipe. Replaces the spinning chain.</p>

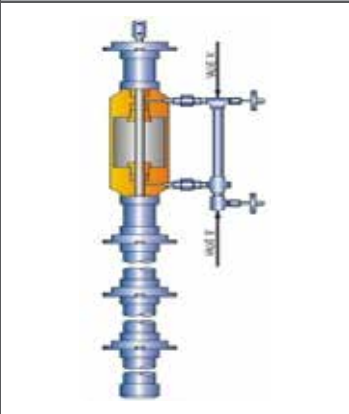
Lubricator	
	<p>Equipment used for installation of back pressure or check valves on the tubing hanger through the production tree with / without pressure from the well exists.</p>

Mousehole	
	<p>Shallow bores under the rig floor, usually lined with pipe, in which joints of drill pipe are temporarily suspended for later connection to the drill string.</p>



## Mud Return Line



A trough or pipe, placed between the surface connections at the well bore and the shale shaker. Drilling mud flows through it upon its return to the surface from the hole.

## Rathole



The Kelly is removed from the drill string before tripping and is stored in the Rathole.

## Rotary Hose



The hose on a rotary drilling rig that conducts the drilling fluid from the mud pump and standpipe to the swivel and Kelly; also called the mud hose or the Kelly hose.



## Rotary Table



The principal component of a rotary, or rotary machine, used to turn the drill stem and support the drilling assembly. It has a beveled gear arrangement to create the rotational motion and an opening into which bushings are fitted to drive and support the drilling assembly.

## Slips



Wedge-shaped pieces of metal with teeth or other gripping elements that are used to prevent pipe from slipping down into the hole or to hold pipe in place. Rotary slips fit around the drill pipe and wedge against the master bushing to support the pipe.

## Power Slips



Power slips are pneumatically or hydraulically actuated devices that allow the crew to dispense with the manual handling of slips when making a connection. Packers and other down hole equipment are secured in position by slips that engage the pipe by action directed at the surface.



## Spinning Chain



A relatively short length of chain attached to the tong pull chain on the manual tongs used to make up drill pipe. The spinning chain is attached to the pull chain so that a crewmember can wrap the spinning chain several times around the tool joint box of a joint of drill pipe suspended in the rotary table. After crew members stab the pin of another tool joint into the box end, one of them then grasps the end of the spinning chain and with a rapid upward motion of the wrist "throws the spinning chain" that is, causes it to unwrap from the box and coil upward onto the body of the joint stabbed into the box. The driller then actuates the makeup cathead to pull the chain off the pipe body, which causes the pipe to spin and thus the pin threads to spin into the box.

## Stairways



Stairs leading from one level to another. Protected with handrails.



## Substructure



The substructure is the drilling rig's foundation up on which the mast and rig floor rests. It gives stability to the entire drilling rig and supports drilling operation of the rig. The substructure of a drilling rig can be classified into the following types: Box on box, skid and trailer, slingshot, spin-up type and telescope type.

## Standpipe



A vertical pipe rising along the side of the derrick or mast. It joins the discharge line leading from the mud pump to the rotary hose and through which mud is pumped going into the hole.

## Surface Casing

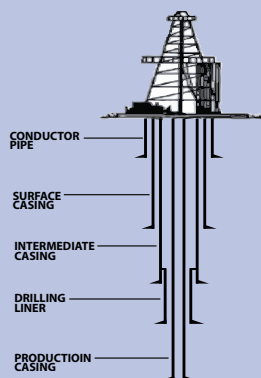

Usually the first casing to be run in a well. This is done after spudding-in so a blowout preventer can be installed before drilling is started.



## Swivel

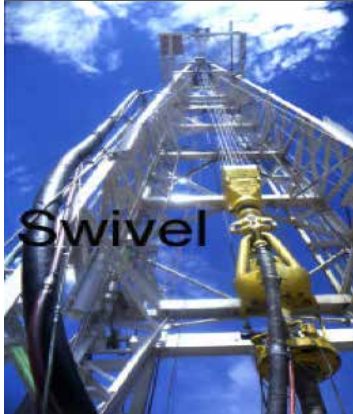

A rotary tool that is hung from the rotary hook and traveling block to suspend and permit free rotation of the drill stem. It also provides a connection for the rotary hose and a passageway for the flow of drilling fluid into the drill stem.

## Tongs



The large wrenches used for turning when making up or breaking out drill pipe, casing, tubing, or other pipe; variously called casing tongs, rotary tongs, and so forth according to the specific use. Power tongs are pneumatically or hydraulically operated tools that spin the pipe up and, in some instances, apply the final makeup torque.

## Walkways



An area cleared for moving through by personnel and protected with a handrail.



### Weight Indicator



A device for measuring the weight of the drill string. Yearly calibration to calculated drill string weight is required.

### SAFETY EQUIPMENT ON RIGS:

### Cascade System



Emergency breathing air system consists of bottle racks with compressed breathing air that shall meet the requirements for type 1-Grade D air as per ANSI standards.

### Self-contained breathing apparatus (SCBA)



A self-contained breathing apparatus (SCBA) or simply Breathing Apparatus (BA) is a device worn by rig crew to receive breathable air in an IDLH (Immediate Danger to Life and Health) Atmosphere.



## Breathing Air Compressor



Used only for supplying type 1-Grade D air to refill the cascade bottles or SCBA bottles.

## Multi Gas Detector



A detector which can detect the presence of one to four gases including oxygen, combustible gases (LEL or  $CH_4$ ), and any two of the following toxic gases such as  $CO$ ,  $H_2S$ ,  $NO_2$  and  $SO_2$ . This type of gas monitors are ideal for confined space monitoring and/or continuous personal monitoring in potentially hazardous environments.

## Fixed Gas Detection System



The fixed type of gas detectors used for detection of one or more gas types for continuous monitoring and alarms can be activated for an emergency situation. Fixed type detectors are generally mounted near the bell nipple, cellar, rig floor and shale shaker areas. The detectors are usually connected using electric cable to the central monitoring system.



# 10. Drilling Rig Types

## Types of Drilling Rig

There are many different type of drilling rigs such as Land Rigs, Drill Ship, Semisubmersibles, Jack ups, and many more (Fig. 11.1). They are different based on where the reservoir is located, the depth of the reservoir, power needed and other factors.



Figure 11.1 Types of Drilling rigs

## Offshore Rig Types

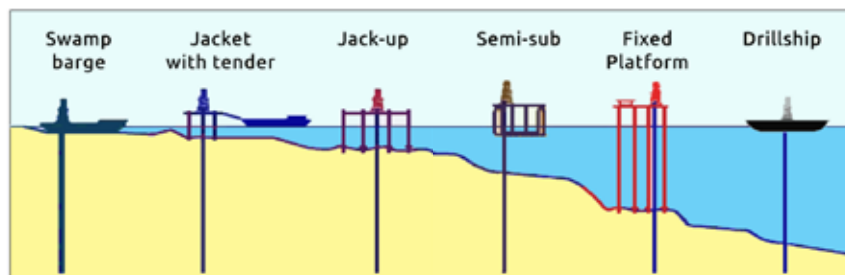

Figure 11.2 Types of Offshore rigs



There are three different rigs used based on Horse Power:

### **1. Work over Rigs**

Workover rigs used to any kind of oil well intervention involving invasive techniques, such as wire line, coiled tubing, snubbing, expensive process of pulling and replacing a completion. A workover rig's engine is smaller than the drilling rig engine. Workover rig HP varies from 350 to 950 HP, but some workover rigs need high HP for deep wells.

### **2. Development Drilling Rigs**

Drilling rig used to drill a well in a known field, so there are plenty of drilling records and experience from drilling many wells in the same field in the past.

The main objective is to drill a well to further develop the field by increasing the recovery and production. These are called "Development Wells."

The engine HP varies from 1000 HP to 3000 HP depending on the rig capacity and the load that can be handling.

### **3. Exploration Operation**

Drilling a well in a new area with no previous drilling experience and record for the area to be drilled. Exploration operations usually propose drilling such a well to find new reserves that require deep drilling (10,000 to 28,000 ft) which use Super Rigs (High HP). The Super Rigs have engine that can generate more than 3,000 HP.

There are many factors that impact the selection of the proper horsepower to use on the drilling rig such as:

1. Depth of the Well for Drilling & Workover.
2. Maximum Weight of string and BHA (Bottom Hole Assembly).
3. Maximum Pump Capacity.
4. Maximum Hoisting Load.
5. Over pull jobs (like Jarring, Fishing, stuck & others).
6. Mud System.



## Types of drilling wells geometries

Wells can be drilled in a number of different geometries from the simplest vertical well to complicated multilateral completions.

There are many different types of well but the most common one are as vertical, deviated, and horizontal well. (Fig. 11.3)

The selection of drilling type is based on the reservoir conditions and economic analysis.

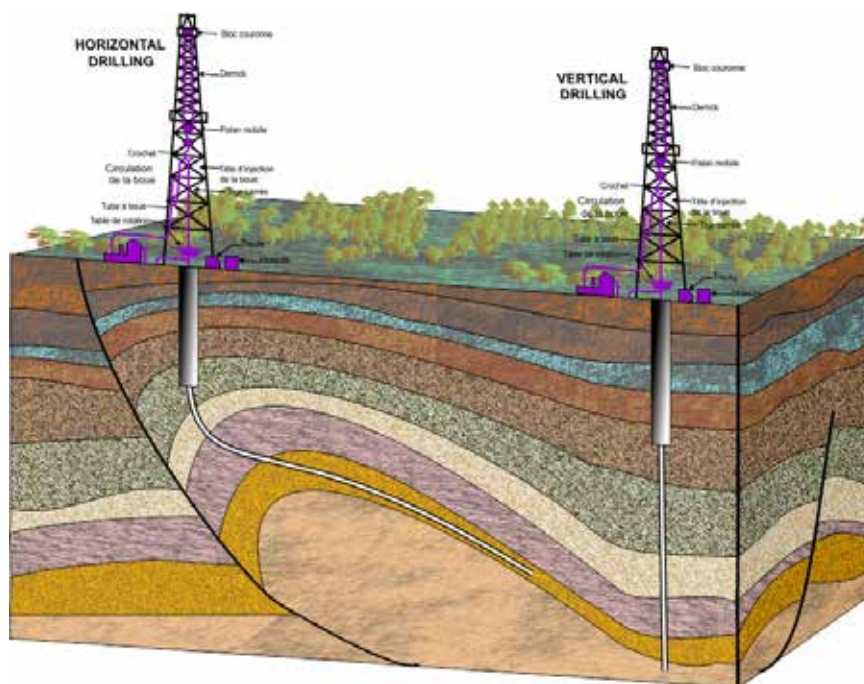

Figure 11.3 Vertical & Horizontal Drilling

Source: [http://www.intragaz.com/en/geophysics\\_drilling.html](http://www.intragaz.com/en/geophysics_drilling.html)

## Vertical Wells

Vertical wells are the most common and conventional wells. They are selected for thick, permeable formations. (Fig. 11.4)

Vertical wells are used with vertical hydraulic fractures for thick, low permeability formations.

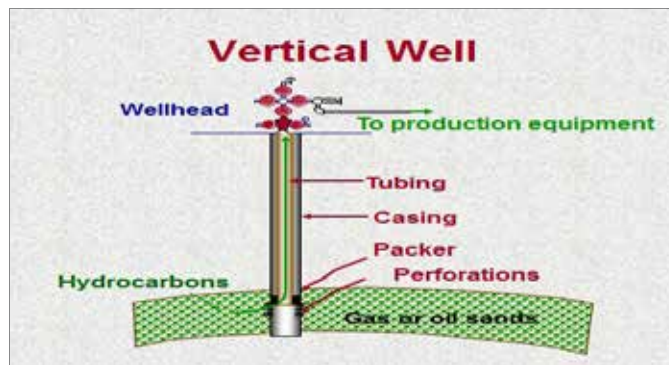

Figure 11.4 Vertical well

## Directional Wells or Deviated Wells

Deviated wells drilling non-vertical holes that purposely deviate from the vertical, using controlled angles to reach an objective location other than directly below the surface location. A directional well may be the original hole or a directional "sidetrack" hole that deviates from the original bore at some point below the surface. (Fig. 11.5)

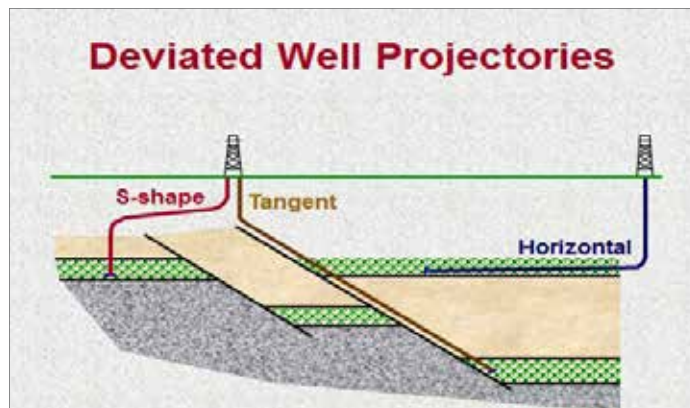

Figure 11.5 Deviated Well

## The Objective of directional drilling:

- Drill multiple wells from the same location.
- To intersect multiple targets (reservoir) from the same well.
- To reach targets below an inaccessible areas for drilling.
- Directional drilling can be utilized to perform sidetrack a fish and avoid drilling in trouble some formation such as salt dome and fault lines.
- To save cost and time.



## Reasons of Directional Drilling

1. Drilling multiple wells from offshore structures with the same rig.

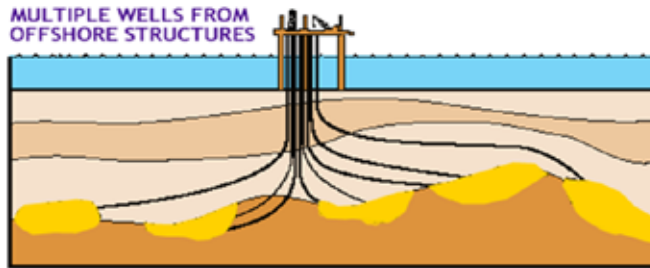

Figure 11.6 Multi Well Drilling

2. Directional drilling technology allows the industry to access deposits underneath obstacles or buildings. Without the directional drilling it maybe otherwise considered as inaccessible.

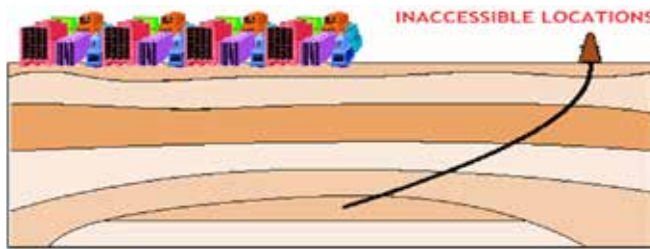

Figure 11.7 Inaccessible Locations

3. Sidetracking

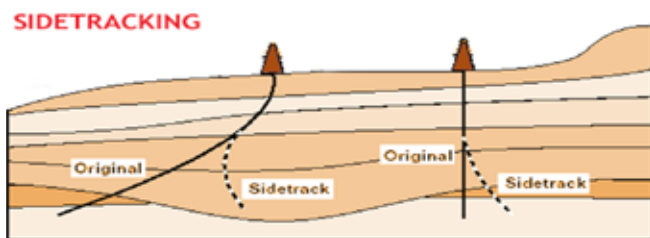

Figure 11.8 Side Tracking

4. Controlling Vertical Drilling

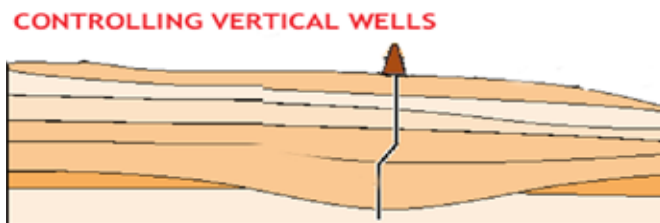

Figure 11.9 Controlling Vertical Drilling



1. Directional drilling can be as a relief well.

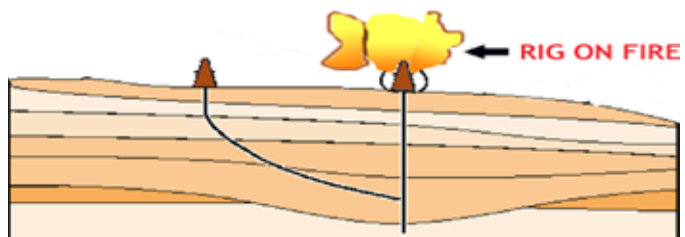

Figure 11.10 Relief well

2. Shoreline Drilling



Figure 11.11 Shoreline Drilling

3. Fault Drilling

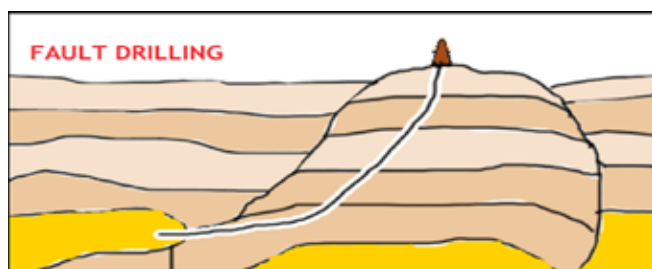

Figure 11.12 Fault Drilling

4. Salt Dome Drilling



Figure 11.13 Salt Dome Drilling



## Horizontal Wells

Horizontal wells are used for thin, permeable formations. Thin oil columns overlaid by gas and/or underlain by water.

Horizontal wells are also used for naturally fractured reservoirs.

The Objective of Horizontal drilling:

- To increase production.
- To reduce water coning problem.
- To reduce sand production problem.
- To intersect vertical natural fractures that are filled with oil and located in a low permeability reservoir.

## Multi- Lateral Wells

A Multi-Lateral well is a well that has one vertical section and several lateral (horizontal) sections.

Multilaterals drilling is used for layered reservoirs to maximize oil/gas production. Multi-Lateral wells combine the benefits of the directional and horizontal wells.

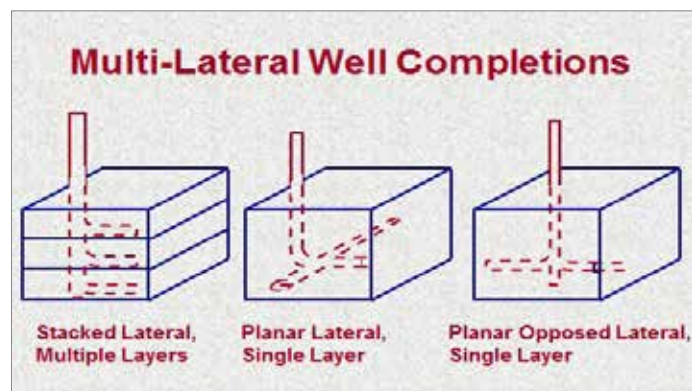

Figure 11.14 Multi-Lateral Well



# 11. Drilling Fluids

A drilling fluid is any fluid (which is circulated through a well in order to remove cuttings from a wellbore. Drilling fluids are air, water, oil or synthetic.

## Drilling Fluid Functions:

- Remove drilled cuttings from under the bit
- Carry the cuttings out of the hole to surface
- Suspend cuttings
- Allow removal of drilled cuttings at surface
- Control downhole pressures
- Cool and lubricate bit and drill string
- Stabilize borehole
- Stabilize reactive formations in borehole
- Prevent damage to reservoir
- Prevent downhole losses
- Remain stable at downhole pressure & temperature
- Prevent corrosion
- Resist contaminants

## Mud Systems

There are several types of mud system used based on the formation, the type of well completion and the well geometry.

There are Fresh Water Muds, Inhibited Mud, Water Base Emulsion and Oil Base & Synthetic Muds.

### Fresh water muds

Fresh water muds uses mud and water as a continuous phase (Spud mud, Lignite mud).

### Inhibited mud

Inhibited mud represses the hydration and subsequent dispersion of clay into the mud (Lime Mud, Gypsum Mud).



There are many advantages of using inhibited mud over the fresh water mud because it tolerates a higher concentration of clays before it develops high viscosity. Also, it has less gelling tendency.

## Water Base Emulsion

When oil and water are mixed together, it is called water base emulsion mud. It has many advantages over the fresh water mud because it reduces the torque in the pipe and reduces the bit balling. It give a better filtration control, it increases the rate of penetration and bit life.

## Oil Base & Synthetic Muds

It is mud that contains oil as continuous phase with only 1 to 5 % of water.

The main advantage of using this type of mud is to drill water sensitive formation such as Shale formation.

Oil base mud & Synthetic mud helps to protect the pay zone.

## Mud properties

The mud needs to be conditioned to maintain certain properties for drilling.

Mud properties can be measure by Density and Rheology.

The mud weight or specific gravity is a key-factor in the control of bottom hole pressures and hole stability. Increase of mud weights, however, causes a considerable reduction in penetration rate and a significant increase in friction losses (viscosity). The mud weight is generally expressed as specific gravity in kg/l or ppg.

## Density

Density is weight per unit volume of drilling fluid. It can be expressed by pounds per gallon (ppg), pounds per cubic feet (pcf), grams per cubic centimeters (g/cc) and kilogram per liter (kg/l).

Mud weight is very important to monitor and maintain because if the mud weight exceeds the fracture pressure of a formation then the formation will fracture. If the mud weight is low, then the hydrostatic pressure will not sustain the formation pressure that leads to the fluids in the formation to flow into the wellbore.



Increase in mud weight could cause many potential problems such as differential sticking and lost circulation.

Whereas, decrease in mud weight could cause influx, unconsolidated formations, geo-pressured formations and mobile formation.

Density can be increased by adding solids or salts. Density can be measured by mud balance (Fig. 12.1).



Fig 12.1 Mud Balance  
Source: [www.eurosul.com/img/fann\\_balanca\\_lama.jpg](http://www.eurosul.com/img/fann_balanca_lama.jpg)

## Rheology

It is the mud parameters such as Viscosity, Plastic Viscosity, Yield Point, Gel Strength, PH, Filtration, Alkalinity, and many more.

## Viscosity

The viscosity is the relationship between shear stress and shear rate. It is a measure of the internal resistance of a fluid to flow. Viscosity is a laminar flow and it has little effect on turbulent flow such as Newtonian fluid and Non-Newtonian fluid (Fig. 12.2).

Newtonian fluids occur when the viscosity is constant with shear rate (Pump Rate).

Non-Newtonian fluids occur when the viscosity changes with shear rate (Pump Rate). Drilling mud is an example of the Non-Newtonian fluids.

The faster the pump rates the thinner the drilling fluids become.

The viscosity of the mud is very important for the optimization of various different mud functions. It is measured in two ways: Marsh Funnel (Fig. 12.3) and Fann Viscometer (Fig. 12.4).

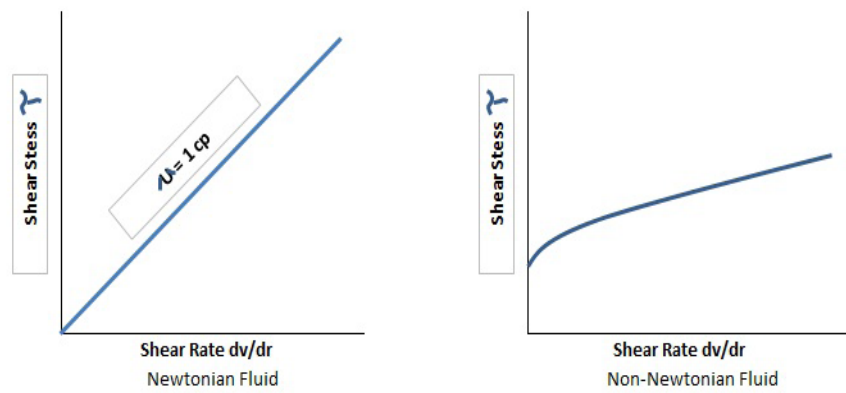

Fig 12.2 Viscosity



Fig 12.3 Marsh Funnel

Source: <http://images-mediawiki-sites.thefullwiki.org/10/3/6/1/35050263407301467.jpg>



Fig 12.4 Fann Viscometer

Source: [http://www.eurosul.us/english/index.php?pag=conteudo&id\\_conteudo=671&idmenu=83&fann-viscometer-model-35](http://www.eurosul.us/english/index.php?pag=conteudo&id_conteudo=671&idmenu=83&fann-viscometer-model-35)



## Plastic Viscosity

It is the difference between the reading at 600 RPM and 300 RPM. The plastic viscosity is affected by the amount of particles in the mud, and size/shape of the particles.

The PV increases when the solids content increases, it decreases when the solids content reduced. Smaller size solids also increase the PV.

It is better to have a low plastic viscosity for the drilling fluid.

## Yield Point

The Yield Point is that part of the resistance to flow caused by attractive forces between particles which causes gel structure to form when mud is at rest.

YP can be calculated by subtracting the PV from the Fann reading at 300 RPM ( $R_{300} - PV$ ). YP can be expressed in lb/100 ft<sup>2</sup>.

## Gel Strength

It is a measurement under static conditions of the forces in the mud that cause gel structure to develop when the mud is at rest.

Gel values are measured after 10 seconds and 10 minutes of static build-up of the mud. A reasonable 10" gel is essential to prevent immediate settling of solids when circulation is stopped.

A large difference between 10" gel and 10' gel indicates a slow but ongoing build-up of structure. Optimally the 10' gel value is 1.5 x the 10" gel value.

## PH

PH is a measure of acidity or alkalinity of drilling mud. PH is expressed in the hydrogen ion concentration. It is used as an aid in determining the type of mud treatment and as an indication of contaminants such as cement and gypsum.

## Filtration

It is the liquid filtrate of the drilling mud. It measures the ability of the solid components to form a thin, low permeability filter cake.



## Common Chemical

Chemical / Material	Function
Barite	Increase the mud density
Bentonite	Fluid loss, filter cake, cutting removal
Caustic Soda	Maintain or increase the basic PH
Soda Ash	Calcium remover (to add polymer)
CMC HV	Provide viscosity
PolyPac R	Controls fluid loss
Polypac UL	Control fluid loss
PolySal	Reduce fluid , increase viscosity
DUO Vis	Increase low shear viscosity
KCL	Drilling water-sensitive shale
Calcium Carbonate	Controlling fluid loss and density
XC Polymer	Increase viscosity at low shear rates
Spersene-CF	Deflocculant and fluid loss additive
M-I PAC R	Tough, thin filter cake



# 12. Solids Control

The solids control main objective is to maintaining drilling fluids and lower the mud costs.

Benefits of solids control include the following:

- Reduce the mud cost.
- Reduce dilution requirements.
- Provide higher penetration rates (faster drilling).
- Reduce the equipment wear.
- Reduce the bit and stabilizer balling effect.
- Reduce the swab and surge pressure.
- Reduce the tendency for differential stuck pipe.
- Reduce torque.

Excessive drilling solids reduce the sweep action of the mud which leads to decrease the bits penetration rate.

Solids can be controlled and separated by mechanical methods such as vibratory screening and centrifugal force.

Solids control equipment:

- Shale Shaker (fig 13.1)
- Desanders and Desilters (fig 13.2 & 13.3)
- Mud Cleaners (fig 13.4)
- Centrifuges (fig 13.5)
- Mud Agitator
- Vertical Slurry pump
- Vacuum Degasser

## Solid control, why it is required and what kind

Anyone familiar with drill site operations is aware that many active mud systems tend to increase in surface volume. The excess must be disposed of by some means after being hauled away or jetted out.



The subsurface mud system consists of the hole. This subsurface system increases at the rate of drilling new hole, plus caving or sloughing rate. Drilling the hole does not change the level in the surface tanks because every 100 bbl of hole drilled adds 100 bbl of cuttings and results in 100 bbl of hole to be filled with mud. The same is true of caved volume, and whether the formation might be bentonite or granite does not change this. The hydration of bentonite by water in the mud system neither shrinks nor expands the volume. It has no effect whatsoever on the system level.

Solids removal involves the removing of large amounts of liquid. Dilution and discard is even worse, with the liquid amounting to between 5 and 20 times the solids volume removed. To successfully drill a deep hole in the ground, all evidence indicates that at least an average of 85% of the hole volume drilled must be removed. No matter how it is done, for every 100 bbl of hole drilled, there will be between 200 and 1,100 bbl of discard, depending upon how we perform the removal. Obviously, the mud system level should be going down, not up!



Fig 13.1 Shale Shaker



Fig 13.2 Desander



Fig 13.4 Mud Cleaners



Fig 13.3 Desilter



Fig 13.5 Centrifuges



# 13. Casing

Casing is a large-diameter pipe lowered into an open hole and cemented in place (Fig. 14.1). Casing is an important process to ensure the stability of the hole and to protect and isolate the fresh water from contamination.

## Casing

Once the hole is drilled, a casing string is lowered into the hole and cemented in place.

Casing is a steel pipe that comes in different types (Fig. 14.2), sizes and strength.

Casing design selection is based on the well conditions and takes into consideration the casing properties such as Casing Grade, Pressure Resistance, Drift diameter and weight.

Drift diameter to guarantee the inside diameter of a pipe or other cylindrical tool by pulling a cylinder or pipe (often called a rabbit) of known outside diameter through it. The drift diameter is the inside diameter (ID) that the pipe manufacturer guarantees per specifications. Note that the nominal inside diameter is not the same as the drift diameter but is always slightly larger. The drift diameter is used by the well planner to determine what size tools or casing strings can later be run through the casing, whereas the nominal inside diameter is used for fluid volume calculations such as mud circulating times and cement slurry placement calculations.

The Casing operations occur periodically throughout the drilling process starting with the surface casing, intermediate casing, and ending with production liner, which takes place during well completion (Fig. 14.3).

## Casing types:

- Conductor pipe
- Surface casing
- Intermediate casing
- Production casing
- Liner:
  - \* Drilling liner
  - \* Production



Fig 14.1 - Casing

Source: <http://www.glossary.oilfield.slb.co>



## Casing objective:

- To protect the foundation that the rig is resting on.
- To protect the fresh water zone from contamination.
- To protect the hole and prevent it from collapsing.
- To control the formation pressure and allow drilling to final depth.
- To isolate producing zones and allow selective fluid production.
- To allow production from multiple zones by using multiple completions.

Casing operations activities can vary based on the casing being installed. The rig crew starts to prepare the casing tools and conduct a pre-job meeting to discuss/coordinate the operations and review role and responsibilities.

Then, the rig crew runs the casing to the desired depth. While running the casing, the rig crew installs additional casing accessories such as centralizers, guide shoe, float collar, etc.

After running the casing and reaching the desired depth, drilling fluid is circulated through the casing and annulus to remove any residual gases and to condition the mud. After circulation and mud conditioning the casing is cemented in place. During the cementing process, the casing is reciprocated or rotated to allow the scratchers to remove excess wall cake and give the cement a better bond.

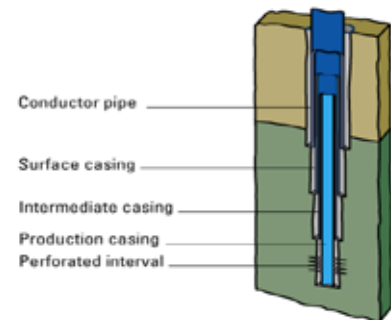

Fig. 14.2 – Casing types  
Source: <http://www.glossary.oilfield>

## Types of Casing

### Conductor Pipe

It is the first casing that is run in the drilling well. The objective of the conductor pipe is to act as a flow line and it provide an installation point for the blow out preventers (BOP). It is known for its large diameter casing and short length between 50 to 250 feet.

### Surface Casing

The surface casing is run through the conductor pipe to provide a better seal the well bore from that may flow into the well bore and protect the fresh water sand from contaminations.

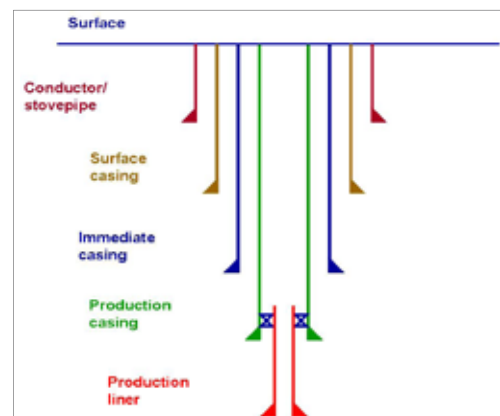

Fig. 14.3 – Casing types



The surface casing provides the well bore stability and it prevent it from collapses. The surface casing comes in different sizes based on the design and the purpose of the casing. The surface casing comes in 9 5/8, 10, 13 3/8, 16, 18 5/8, 20 and 24 inches.

Usually runs between 200 to 5000 feet in length.

## Intermediate Casing

The intermediate casing is after the first casing and the main purpose of the intermediate casing is to seal the well bore from the fluids and to provide a protection against the formation pressure.

It comes in different sizes, between 4 1/2 to 13 3/8 inches. It is set between 2000 to 20,000 feet in depth.

## Liner

If the casing string is hung at some point of depth and not being run up to the surface then it is called liner. The top of the liner sets inside on the casing string.

## Production Liner

The production liner is run through the productive zone. The upper part of the casing string is usually cemented up to 300 to 500 feet to ensure good seal.

## Production Casing

The production casing is the last casing and runs from the surface up to the productive zone. It should be designed carefully because it should withstand all the wellhead shut in pressure in case the tubing or the packer fails.

## Production Tubing

The production tubing purpose is to carry the hydrocarbons to the surface from the productive zones. The production tubing is run into the drilled well after the casing is run and cemented in place.

Production tubing protects casing string from wear and tear. Also, it protects the casing string from possible corrosion, and deposition of hydrocarbons products which might lower the production ability and the production rate that is why the tubing is usually replaced in regular basis.

Like casing, type and size of the production tubing depends on well conditions. The production tubing diameter is between five and ten centimeters.

It is held inside the casing through the use of expandable packing devices.



**Commonly Used Bit Sizes That Will Pass Through API Casing**

Casing Size ,OD, in.	Weight/ft,lbm/ft	ID.in	Drift Diameter.in.	Commonly Used Bit Sizes.in.
4 1/2	9.5	4.090	3.965	3 7/8
	10.5	4.052	3.927	
	11.6	4.000	3.875	
	13.5	3.920	3.795	3 3/4
5	11.5	4.560	4.435	4 1/4
	13.0	4.494	4.369	
	15.0	4.408	4.283	
	18.0	4.276	4.151	3 7/8
5 1/2	13.0	5.044	4.919	4 3/4
	14.0	5.012	4.887	
	15.5	4.950	4.825	
	17.0	4.892	4.764	
	20.0	4.778	4.653	4 5/8
	23.0	4.670	4.545	4 1/4
6 5/8	17.0	6.135	6.010	6
	20.0	6.049	5.924	5 5/8
	24.0	5.921	5.796	
	28.0	5.791	5.666	
	32.0	5.675	5.550	4 3/4
7	17.00	6.538	6.413	6 1/4
	20.00	6.456	6.331	
	23.00	6.366	6.241	
	26.00	6.276	6.151	6 1/8
	29.00	6.184	6.059	6
	32.00	6.094	5.969	
	35.00	6.006	5.879	
	38.00	5.920	5.795	5 5/8
7 5/8	20.00	7.125	7.000	6 3/4
	24.00	7.025	6.900	
	26.40	6.969	6.844	
	29.70	6.875	6.750	
	33.70	6.765	6.640	6 1/2
	39.00	6.625	6.500	
8 5/8	24.00	8.097	7.972	7 7/8
	28.00	8.017	7.892	
	32.00	7.921	7.796	6 8/10
	36.00	7.825	7.700	
	40.00	7.725	7.600	
	44.00	7.625	7.500	
	49.00	7.511	7.386	
9 5/8	29.30	9.063	8.907	8 3/4, 8 1/2
	32.30	9.001	8.845	
	36.00	8.921	8.765	
	40.00	8.835	8.679	8 5/8, 8 1/2
	43.50	8.755	8.599	
	47.00	8.681	8.525	8 1/2
10 3/4	53.50	8.535	8.379	7 7/8
	32.75	10.192	10.036	9 7/8
	40.50	10.050	9.894	
	45.50	9.950	9.794	9 5/8
	51.00	9.850	9.694	
	55.00	9.760	9.604	
	60.70	9.660	9.504	8 3/4, 8 1/2
	65.37	9.560	9.404	8 3/4, 8 1/2
11 3/4	38.00	11.154	10.994	11
	42.00	11.084	10.928	10 5/8
	47.00	11.000	10.844	
	54.00	10.880	10.724	
	60.00	10.772	10.616	
13 3/8	48.00	12.715	12.559	12 1/4
	54.50	12.615	12.459	
	61.00	12.515	12.359	
	68.00	12.415	12.259	
	72.00	12.347	12.191	11
16	55.00	15.375	15.188	15
	65.00	15.250	15.062	
	75.00	15.125	14.939	14 3/4
	84.00	15.010	14.822	
	109.00	14.688	14.500	
18 5/8	87.50	17.755	17.567	17 1/2
20	94.00	19.124	18.936	17 1/2



# 14. Cementing

When the casing string is lowered into the hole then the casing is cemented in place. Cement is pumped in the annulus which is the space between the drilled hole and the casing.

Cementing is very similar to the casing, it serves the almost the same purpose and furthermore, it protect the casing from corrosion.

Different type of cement is used based on the well conditions and other factors.

## **Cementing objective**

- Normal cement plus additives is used to cement the casing in place.
- Provide zone isolation.
- Protect casing from possible corrosion.
- Protect casing from external pressure that could collapse the pipe.
- Prevent unwanted migration of fluid.
- Prevent pollution of oil.
- Control high pressure zone.

The Cement process starts with well analysis and identifying the requirement to execute the job. Slurry design and test process, mixing process come next and finally pumping process.

## **There are two main oil well cementing activities:**

- Primary Cementing
- Secondary Cementing

Primary cementing is the process of mixing and injecting a volume of cement slurry in the annular space between the casing and the wellbore. Whereas secondary cementing is performed for some special purposes such as cement plug to solve problems in the wellbore.



Figure 15.1 Banana Truck (carries cement powder)



Figure 15.2 Batch mixer



Figure 15.3 Cementing Unit

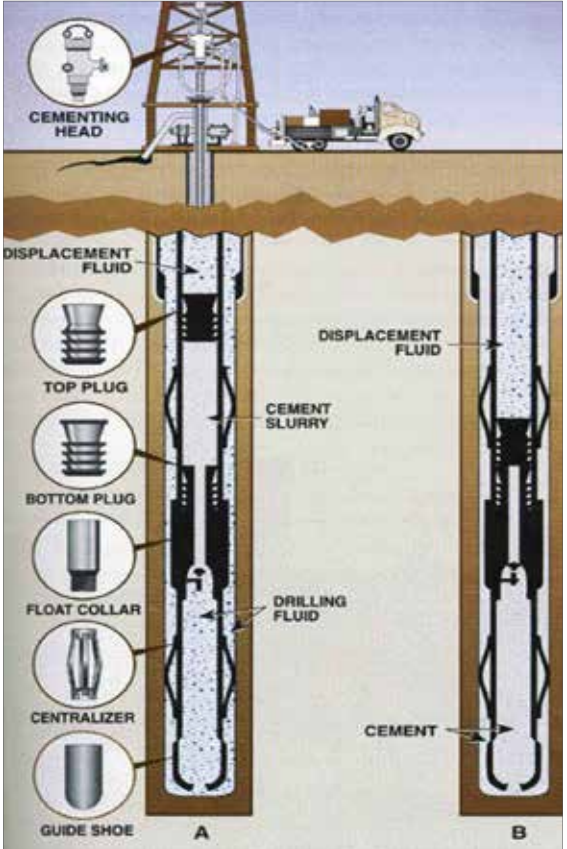

Fig 15.4 Cementing Equipment  
Source: <http://mpgpetroleum.com>



# 15. Companies

## Operating Company

An operating company's primary business is exploring and production of oil and gas.. The operating company obtains the right to drill oil wells to produce oil at a particular site or area.

## Drilling Company

Most operating companies find it more cost effective to hire expertise and equipment from drilling companies/contractors. Drilling companies are responsible for drilling activities based on operating company objectives and programs.

Operating company and drilling contractors sign an agreement called a drilling contract which describes the drilling project, determines the cost of each operation and states the type of services.

## Service Company

Service companies provide the required tools and services necessary to complete the drilling of the well. These services include sales of chemicals, mud, cement, logging, wire-line, running casing and installing wellheads, etc.



# 16. Rig Personnel

## Rig Personnel

Drilling a well requires hiring many skillful employees to run the rig and operate the drilling operations. Each one of them is very important and has to have a full awareness of the drilling operations to ensure safety. There are two shifts, each work for 12 hours. Each shift consists of a driller, assistant driller, Derrick man, Roughnecks, and Floor hands. The tool pusher oversees the drilling crew and ensures to keep the drilling operations going according to the drilling program.

## Rig Superintendent – Tool Pusher

The Tool Pusher works for the drilling contractor. The Tool Pusher supervises the drilling crew and coordinates between the drilling contractor and the operating company. He is responsible for the drilling operations and the drilling crew.

## Night Tool Pusher

Works directly under the instruction of the Tool Pusher as the second person in charge on all operations and job. Relieves the Tool Pusher during his shift (Day/Night). In addition to being the overall charge in cases where the Tool Pusher is not on board the rig or incapable of carrying out his duties as Tool Pusher

## Driller

The Driller operates drilling equipment to drill the hole of the well and supervise the drilling crew such as the assistant driller, derrick man, and floor hands (also called rotary helpers or roughnecks). The driller operates from the driller's console to maintain proper bit weight, pump rate, pump pressure and RPM. The Driller works 12 hours per shift.

## Assistant Driller

Assistant Driller assists the driller in the drilling operations and helps him out to monitor the drilling operations parameters and supervise the rest of the drilling crew on the rig floor.



## Derrick man

The Derrick Man is responsible for handling the upper part of the pipe from the derrick's monkey board while tripping. He maintains mud and solids control equipment while drilling. He also maintains the crown block.

The Derrick Man has to wear fall protection equipment when working at heights to prevent him from falling and keep him safe.

## Floor hands

Floor hands usually consist of two to three floor hands depending on the size of the rig, the rig operations and many other factors. Floor hand work on the rig floor near the rotary table and they work in rough working tasks such as handling drill pipes connections or drill pipes disconnections, using large wrenches called tongs to screw and unscrew the pipe.

Floor hands also maintain the rig equipment, repairing the rig equipment, cleaning the rig floor and the equipment, and painting.

Floor hands are also called rotary helpers, or roughnecks.

## Additional Personnel:

### Electrician

Responsible for rig electricity devices and maintains the condition of these devices to run smoothly without any major shutdowns.

### Mechanic

Responsible for the rig engine devices and maintains the condition of these devices to run smoothly without any major shutdowns.

### Drilling Fluids Engineer / Mud Engineer

Responsible for the mud properties and mud analysis during the drilling operation to help out the drilling operations and adding chemical additives based on the well conditions.



The mud is very similar to the human blood in a way. It is very important for the system and brings energy and it cleans the system.

For that reason the Drilling Fluid Engineer is called the Mud Doctor, he diagnose what is wrong with the mud and the system overall and ensures that the drilling operation remains fit and healthy, which is the same as the normal doctor who checks the blood for anything abnormal. He checks for any genetic defects (downhole problems) and the blood disorders (contaminants).

He must be knowledgeable of the total system (formation and well), so he can prescribes the appropriate remedial treatments to ensure the correct problems and maintain a chemical balance to maximize performance.

## Safety officer

He is responsible for the safety on the rig and supervises the rig operations. He mitigates the hazards on the rig and work to eliminate or minimize the impact of these hazards.

## Medic

Medic do minor medical checks and first aid to the rig crew.

## Forklift Operator

He operates the forklift and other similar types of machinery to help out with the operations.

## Crane Operator

The Crane Operator is responsible for the safe and efficient operation and general maintenance of the various cranes located on the drilling rig. He is responsible for safety and efficiently lifting and moving/relocating equipment, containers, pipes, systems and various materials and supplies utilized in the operations and daily functions of the drilling rig.

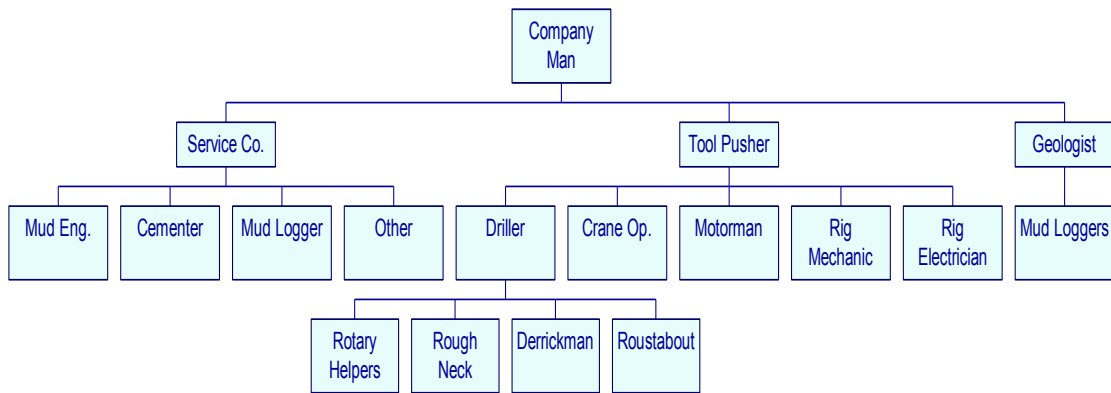

Fig 17.1 Rig Personnel Chart



Fig 17.2 Rig Crew

Source: <http://oilrigdrillings.com/2011/12/30/oil-rig-worker/>

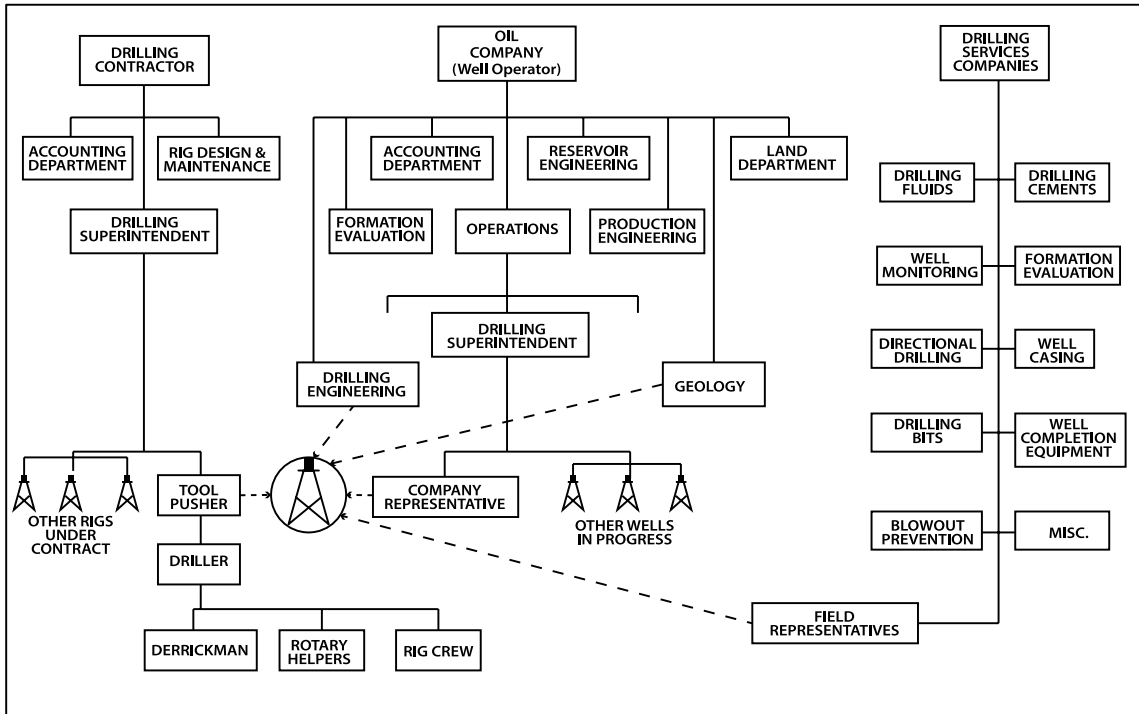

Fig. (1.1) Typical drilling organization

Sr No	Position	Assign Total for rig	On Duty	Rotation
1	Drilling Supervisor	2	1	28/28
2	Senior Toolpusher	2	1	28/28
3	Toolpusher	2	1	28/28
4	Drillers	4	2	28/28
5	Assistant Drillers	4	2	28/28
6	Derrickmen	4	2	28/28
7	Floormen	12	6	28/28
8	Chief Mechanic	2	1	28/28
9	Welder	2	1	28/28
10	Mechanic Motorman	4	2	28/28
11	Electrician	2	1	28/28
12	Crane Operator	2	1	28/28
13	Forklift Operator	2	1	28/28
14	HSE Officer	2	1	28/28
15	Crew Bus Driver + other drivers	4	2	28/28
16	Security	4	2	28/28



# 17. Drilling Problems

There are many problems that might occur while drilling such as:

- **Lost circulation**

Lost circulation happens when there is uncontrolled flow of drilling fluids comes into down hole formation. This can be either a partial loss, some returns to the surface or a complete loss with no returns to the surface. This happens when the drilling encounters a highly fracture zone, one with low pressure-high permeability or a cave-in and weak formations. If drilling is continued with no returns it is called dry or blind drilling.

Lost circulation problem could lead to high costs and could be an expensive problem in drilling.

Lost circulation problem could happen at any depth regardless of the mud type or the mud weight which being used.

Poor cement job is the most common cause for lost circulation.

The best solution to this problem is to:

- Maintain proper mud weight
- Minimize annular friction pressure
- Maintain adequate hole cleaning
- Set casing to protect weaker formations
- Treat mud with loss circulation materials if anticipated.

When loss circulation happens, then the best thing to do is:

- Determine the theirf zone,
- Determine the size of the theirf zone to prepare the recipe for the LCM to be used
- Determine the rate of loss,
- Pump LCM
- Seal the zone with cement if need be
- Set casing and
- Drill through cement.Drill Pipe Failures



There are common drill pipe failures such as:

- Twist off
- Parting
- Burst or collapse
- Fatigue
- Leaking / washout

Most of these are prevented by starting with a good string. Drill pipe and collars should be constantly inspected, and regularly tested as per API RP-7G, DS-1.

- **Differential and Mechanical sticking of drilling string**

Pipe Sticking happens during the inability to move or rotate the pipe. There are two types of sticking, differential and mechanical sticking.

## Differential Sticking

There are several factors that might causes of differential sticking such as:

- High differential pressures (over balance)
- Thick mud cake (continuous high fluid loss to formation)
- Low-lubricity mud cake (high coefficient of friction)
- Pipe left stationary for some time (delay in operations).

Several signs indicate the pipe differential sticking such as:

- Increase in torque and drag.
- Inability to move the pipe.
- Circulation of drill fluid is interrupted.

There are ways to minimize differential sticking such as:

- Using proper mud characteristics (weight, fluid loss)
- Using collar shape (spiral or square collars)
- Keep drilling solids low in the mud
- Keep rotating the drill string



## Mechanical Sticking

Mechanical Sticking happens when a high accumulation of cuttings accumulates in the annulus. Usually it happens in wells that do not have efficient well hole cleaning. This problem is common in directional or horizontal wells.

Increase in circulating pressure while drilling, or increase in drag when tripping is a good indication of the problem. It is a good idea to circulate bottoms up before tripping the pipe as this cleans the hole.

There are ways to minimizing mechanical sticking such as:

- Using efficient drilling hydraulics, rate and viscosity
- Using high rotation rate in directional holes

- **Hole Deviation**

The bit tends to walk while drilling when the hole deviates from the vertical or planned course. The formation dip and rock properties can influence the path of the bit.

This can be a result of:

- Using improper drill string that suits the formation
- Having insufficient Weight on bit.
- Rock characteristics and rock nature which can lead to deviation in the hole.
- Using improper RPM of the drill string.

The hole deviation problem can be corrected by changing the BHA or by adding more stabilizers. Lowering the Weight on bit & slowing the rotation can also happen to minimize the problem.

Hole deviation is also known as "dog leg problem".

- **Borehole Instability**

Borehole Instability problems are common in shale sections of the hole. Shale can plastically flow inward or slough causing mechanical sticking.

Salt also exhibits plastic behaviors. Any weak formation can collapse if the mud weight higher than the formation pressure. Indications of trouble are an increase in the torque, increase in circulating pressure



or even the blocking of returns to the surface.

Borehole instability problems can be caused by erosion due to drilling fluid and the nature of the corrosive materials. Also, it can be caused by chemical reaction between the formation and the fluids. Or even from the mechanical stresses while drilling.

To prevent the borehole instability starts with having a good mud design, maintain and control the mud weight and water loss.

- **Corrosion**

The corrosion happens when destruction of metal by chemical or electrochemical interaction with the environment. The drill pipe gets affected by the corrosion and as result of this the pipe gets weaker and weaker till the pipe failure and cause washouts.

Carbon dioxide (CO<sub>2</sub>) and Hydrogen sulfide (H<sub>2</sub>S) and dissolved oxygen (O<sub>2</sub>) are the main corrosive materials.

There are influencing factors such as temperature, fluid chemical composition, velocity, pressure.

There are ways to minimize the impact of corrosion by close monitoring and maintenance.

- **Bit Balling**

Bit balling happens when shale formation forms soft and sticky clay when exposed to water. Sticky clay can adhere to water wet metal. This problem can become serious when the clay starts to block the annulus or cover the bit completely.

There are ways to prevent the bit balling by maintain good bit and hole cleaning.

- **Torque and Drag**

Torque is rotational resistance arising from contact with the wellbore. Drag is the linear resistance. Excessive wall contact and sticky clays can increase the torque and drag. The drilling efficiency reduced when we have the torque and drag problem. Additives such as lubricants can be added to minimize the effect of the torque and drag problem.



- **Key Seat**

The key seat is formed when drill string is not aligned right or the hole is not straight. That drill string start to press against the side of the hole and as a result of that a cutting groove gets formed, so when pulling out of the hole the BHA will catch on the groove. That is why it is always recommended to keep the hole in proper alignment.

Two conditions frequently contribute to potential key seating problems. One is related to doglegs in the hole so that pipe is pulled into the wall with considerable lateral force while drilling. This condition is illustrated by Fig. A. The second condition is when ledges that are close to gauge hole are left in areas of washed-out hole sections, as shown in Fig. B.

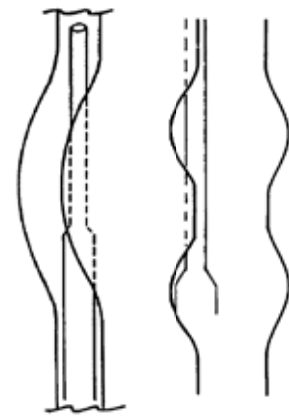

Fig. A

Fig. B

- **H<sub>2</sub>S**

H<sub>2</sub>S is Hydrogen sulfide. It is a poisonous gas. Hydrogen sulfide is a serious hazard. H<sub>2</sub>S has the odor of rotten eggs at low concentrations but it is odorless at high concentrations.

Even in low concentrations, H<sub>2</sub>S is hazardous to workers and sometimes can be lethal. The effect of H<sub>2</sub>S depends on duration, frequency and intensity of exposure as well as the susceptibility of the individual.

H<sub>2</sub>S stress cracking is a hydrogen embrittlement phenomenon, where the equipment in contact with H<sub>2</sub>S containing liquid undergo atomic reactions and cracks develop.

For this reason, it is essential to control the hazard of Hydrogen sulfide by the following:

- Crew adequate training & conduct H<sub>2</sub>S drills.
- Conduct Pre-job meetings.
- Install H<sub>2</sub>S Detection devices.
- Using Respiratory Equipment.
- Implement safe work procedures.
- Implement emergency response procedures.
- Monitor H<sub>2</sub>S concentration in the rig.
- Good maintenance of H<sub>2</sub>S devices & NACE certifications.
- Planning ahead.



- **Fishing**

If a tool is lost or the drill string breaks, the obstruction in the well is called junk or fish. It cannot be drilled through. Special grabbing tools are used to retrieve the junk in a process called fishing. In extreme cases, explosives can be used to blow up the junk and then the pieces can be retrieved with a magnet.

- **Well control**

Well control is very critical to the safety of the whole drilling operation and the crew. Well control can be an issue when having a kick. A kick is an entry of formation fluid such as water, gas and oil or other formation fluid into the borehole. If the well is left uncontrolled a kick can develop into a blowout (uncontrolled release of crude oil and/or natural gas from an oil well or gas well after pressure control systems have failed).

Well control procedures might vary from one rig to another and from one company to another.

There are several safety measures to control the well such as:

1. Rig control

BOP's, FOSV, Mud pumps, Draw works and other rig equipment. The driller is responsible for rig control equipment.

2. Mud Control

The Mud engineer and the Derrick man operate the mixing system and chemical addition to have a good mud mixture that suits the drilling situation and the drilling formation. Chemical addition operations are usually an addition of weighting material such as barite to the mud to increase its density. Kill mud reserve is maintained in case of an emergency.

3. Choke Control

The Driller & A/D calculates the relationship between pressures and time.

The Driller & A/D should be the best trained employee on the rig in kick control.

The rig superintendent or the tool pusher will supervise these three well control measures to ensure the well control operations and the safety of the operations.

It is very important to have a written well control manual with policies and procedures in details to avoid confusion and wasting critical time during a kick.



# 18. Calculations

## 1. Volumes & Capacities:

- **Pipe Capacity, bbls/ft.**

$$\text{Pipe Capacity, bbls/ft.} = \frac{\text{ID}^2, \text{ inches}}{1029.4}$$

$$\text{Pipe Capacity, m}^3/\text{m} = \frac{\text{ID}^2, \text{ millimeters}}{1,273,000}$$

- **Annular Capacity, bbls/ft.**

$$\text{Annular Capacity, bbls/ft.} = \frac{\text{Dh}^2 - \text{dp}^2}{1029.4}$$

Dh= Diameter of Hole wall, inches

dp= Tubular OD, inches

- **Casing Capacity, bbls/ft.**

$$\text{Casing Capacity, bbls/ft.} = \frac{\text{ID}^2}{1029.4}$$

- **Volume, bbls**

$$\text{Volume, bbls} = \text{Capacity, bbls/ft.} \times \text{Length, ft}$$

- **Pumps**

- **Triplex Pump**

$$\text{Pump output, bbl/stroke} = 0.000243 \times (\text{Liner ID, in})^2 \times \text{Stroke} \times \text{efficiency} \%$$

- **Duplex Pump**

$$\text{Pump output, bbl/stroke} = 0.000162 \times (2 \times \text{Liner ID, in})^2 - (\text{ROD, in})^2 \times \text{Stroke} \times \text{efficiency} \%$$

- **Pump Rate**

$$\text{Pump Rate, bbl/min} = \text{Pump output, bbl/stroke} \times \text{SPM, stroke per minute}$$

$$\text{Pump Rate, gal/min} = 42 \times \text{Pump output, bbl/stroke} \times \text{SPM, stroke per}$$



minute

- **Time, Minutes**

$$\text{Time} = \frac{\text{Volume (bbls)}}{\text{Pump Output } \left(\frac{\text{bbls}}{\text{Stk}}\right) \times \text{SPM (Stks/min)}}$$

## 2. Tripping:

- **Buoyancy Factor**

$$\text{Buoyancy Factor} = \frac{65.44 - \text{Mud Weight, ppg}}{65.44}$$

Example: If the mud weight is 10.0 ppg.

What is the Buoyancy Factor?

$$\text{Buoyancy Factor} = (65.44 - 10 \text{ ppg}) \div 65.44$$

$$\text{Pressure Gradient in psi/ft.} = 0.847$$

- **Buoyed Weight, lbs**

$$\text{Buoyed weight} = \text{Dry Weight, lbs/ft.} \times \text{Buoyancy Factor}$$

Example: If the dry weight per foot is 90 lbs and using the previous example buoyancy factor.

What is the Buoyancy Weight?

$$\text{Buoyancy Weight} = 90 \text{ lbs} \times 0.847$$

$$\text{Buoyancy Weight} = 76.23 \text{ lbs}$$

- **Steel Displacement**

$$\text{Displacement, bbls/ft.} = \frac{\text{Dry Weight, lbs/ft}}{2747}$$

Example: If the dry weight of Pipe is 19.5 lbs/ft.

What is the Displacement?

$$\text{Displacement} = 19.5 \text{ lbs/ft.} \div 2747$$

$$\text{Displacement} = 0.00709 \text{ bbls/ft.}$$



- **Slug Calculations**

- **Slug Volume**

$$\text{Slug Volume, bbls} = \frac{(\text{M.Wt.,ppg} \times \text{L.dry.ft} \times \text{Pipe Cap, } \frac{\text{bbls}}{\text{ft}})}{(\text{Slug Wt.,ppg} - \text{Mud Wt.,ppg})}$$

M. Wt. = Mud Weight, ppg

Pipe Cap. = Pipe Capacity, bbls/ft.

L. dry. = Level drop in mud below rotary table in feet

Example: If the mud weight is 10 ppg, Level drop in mud below rotary table 200 feet, slug weight is 12 ppg and pipe capacity is 0.01776 bbls/ft.

What is the Slug Volume?

$$\text{Slug Volume} = 10 \text{ ppg} \times 200 \text{ ft.} \times 0.01776 \text{ bbls/ft.} \div (12 - 10) \text{ ppg}$$

$$\text{Slug Volume} = 17.76 \text{ bbls}$$

- **Slug Weight**

$$= \frac{(\text{M.Wt.,ppg} \times \text{L.dry.ft} \times \text{Pipe Cap, } \frac{\text{bbls}}{\text{ft}})}{\text{Slug Volume, bbls}} + \text{M. Wt., ppg}$$

M. Wt. = Mud Weight, ppg

Pipe Cap. = Pipe Capacity, bbls/ft.

L. dry. = Level drop in mud below rotary table in feet

Example: If the mud weight is 10 ppg, Level drop in mud below rotary table 200 feet, slug Volume is 20 bbls and pipe capacity is 0.01776 bbls/ft.

What is the Slug Weight?

$$\text{Slug Weight} = [10 \text{ ppg} \times 200 \text{ ft.} \times 0.01776 \text{ bbls/ft.} \div (20) \text{ bbls}] + 10 \text{ ppg}$$

$$\text{Slug Weight} = 11.77 \text{ ppg}$$

- **Level Drop when Tripping (Dry Pipe)**

$$\text{Level Drop/Stand} = \frac{(\text{Metal Disp., } \frac{\text{bbls}}{\text{ft}} \times \text{Stand Length})}{(\text{Casing Cap., } \frac{\text{bbls}}{\text{ft}} - \text{Metal Disp., bbls/ft})}$$

Metal Disp. = Metal Displacement, bbls/ft.

Casing Cap. = Casing Capacity, bbls/ft.



Example: Due to pulling pipe out of hole, Metal Displacement is 0.00797 bbls/ft., Casing capacity without any pipe in hole is 0.1522 bbls/ft., Mud Weight is 10.5 ppg, and using stands with length of 93 feet.

What is the Level Drop/Stand?

$$\text{Level Drop} = (0.00797 \text{ bbls/ft.} \times 93 \text{ ft.}) \div (0.1522 - 0.00797) \text{ bbls/ft.}$$

$$\text{Level Drop} = 5.14 \text{ ft.}$$

- **Pressure Drop when Tripping (Dry Pipe)**

$$\text{Pressure Drop/Stand} = \text{Level Drop, ft.} \times \text{M. Wt., ppg} \times 0.052$$

What is the Pressure Drop/Stand for the previous example?

$$\text{Pressure Drop/Stand} = (5.14) \text{ ft.} \times (10.5) \text{ ppg} \times 0.052$$

$$\text{Pressure Drop} = 2.8 \text{ psi}$$

- **Level Drop for Drill Collars**

$$\text{Level Drop/Stand} = \frac{(\text{Metal Disp., } \frac{\text{bbls}}{\text{ft.}})}{(\text{Casing Cap., } \frac{\text{bbls}}{\text{ft.}})} \times \text{Collar Length, ft.}$$

Metal Disp. = Metal Displacement, bbls/ft.

Casing Cap. = Casing Capacity, bbls/ft.

Example: Due to pulling pipe out of hole, Metal Displacement is 0.00797 bbls/ft., Casing capacity without any pipe in hole is 0.1522 bbls/ft., Mud Weight is 10.5 ppg, and using collar length of 90 feet.

What is the Level Drop/Stand?

$$\text{Level Drop} = \frac{(0.00797 \text{ bbls/ft.})}{(0.1522 \text{ bbls/ft.})} \times 90 \text{ ft.}$$

$$\text{Level Drop} = 4.71 \text{ ft.}$$

- **Pressure Drop wet pipe**

We can use this when there is no mud returns on the trip tank via Mud Bucket.

$$\text{Pressure Drop/ Stand} = \left[ \frac{(\text{Mud Gradient} \times (\text{Metal Disp.} + \text{DP Cap.}))}{\text{Annular Capacity}} \right] \times \text{Stand Length, ft.}$$



**Annular Capacity = Casing Capacity – (Metal Displacement + Pipe Capacity)**

Mud Gradient = psi/ft.

Casing Cap. = Casing Capacity, bbls/ft.

- **Length of Drill Collars to pull**

Amount of Drill Collars to pull to achieve a required level drop

$$\text{Length of Collar} = \frac{(\text{Casing Cap.}, \frac{\text{bbls}}{\text{ft}})}{(\text{Metal Disp.}, \frac{\text{bbls}}{\text{ft}})} \times \text{Level Drop Required, ft.}$$

Metal Disp. = Metal Displacement, bbls/ft.

Casing Cap. = Casing Capacity, bbls/ft.

Example: Level drop required is 25 ft., Metal Displacement is 0.0546 bbls/ft., Casing capacity without any pipe in hole is 0.1522 bbls/ft.

What is the Length of Drill Collar to pull?

$$\text{Level Drop Length of collar to pull} = \frac{(0.1522 \text{ bbls/ft})}{(0.0546 \text{ bbls/ft})} \times 25 \text{ ft.}$$

= 69.7 ft.

## 1. Stuck Pipe:

- **Free Length of Stuck Pipe (Steel Pipe)**

$$\text{Length of Collar} = \frac{(735,294) \times (e, \text{inches}) \times \text{Wdp., lbs/ft}}{(\text{Differential Pull, lbs})}$$

e = differential stretch of pipe , inches

Differential Pull = Differential pull to obtain 'e', lbs

Wdp. = Drill pipe Plain End \* Weight, lbs/ft.

Example: If differential stretch of pipe 'e' is 24 inches, Differential pull is 30,000 lbs, Drill pipe Plain End \*weight 'Wdp' is 17.93 lbs/ft.

What is the Free Length of Stuck Pipe in feet?

$$\text{Free length of stuck pipe} = \frac{(735,294) \times (24 \text{ inches}) \times (17.93 \text{ lbs/ft})}{(30,000 \text{ lbs})}$$



$$\text{Free length of stuck pipe} = \frac{(316,411,714 \frac{\text{lbs}}{\text{ft}})}{(30,000 \text{ lbs})}$$

Free length of stuck pipe = 10,547 ft.

#### ▪ **Stretch of Suspended String**

Stretch due to own weight

$$\text{Stretch, in} = \frac{[(\text{Length of String, ft})^2]}{96,250,000} \times [65.44 - (1.44 \times \text{Mud Wt., ppg})]$$

Example: Length of string is 10,520 ft., Mud weight is 11 ppg.

What is the suspended string stretch due to own weight?

$$\text{Stretch} = \frac{(10,520 \text{ ft})^2}{(96,250,000)} \times [65.44 - (1.44 \times 11)]$$

Stretch = 1.1498 x 49.6 = 57 inches

#### ▪ **General Stretch**

Stretch due to weight on end of steel pipe

$$\text{Stretch, in} = \frac{[\text{Stretching Force, lbs} \times \text{Pipe length, ft}]}{1,963,500 \times (\text{Pipe OD}^2 - \text{Pipe ID}^2)}$$

OD = Pipe Outside Diameter, inches

ID = Pipe inside Diameter, inches

Example: Length of pipe is 800 ft., Casing weight attached to end of pipe is 350,000 pounds. Pipe OD is 5 inches and pipe ID is 4.276 inches.

What is the stretch due to weight on end of steel pipe?

$$\text{Stretch} = \frac{(350,000 \text{ lbs} \times 800 \text{ ft})}{1,963,500 \times (5^2 - 4.276^2)}$$

$$\text{Stretch} = \frac{(280,000,000)}{1,963,500 \times (6.7158)}$$

$$\text{Stretch} = \frac{(280,000,000)}{13,186,520}$$

Stretch = 21.2 inches



- **Plain End weight, lbs/ft.**

weight of steel pipe (excluding tool joints)

$$\text{Stretch, in} = 2.67 \times (\text{Pipe OD}^2 - \text{Pipe ID}^2)$$

OD = Pipe Outside Diameter, inches

ID = Pipe inside Diameter, inches

- **Maximum Over pull (MOP)**

Overall pull in pounds, allowed on stuck pipe.

$$\text{MOP}^* = (\text{Pa (S)} \times 0.9) - \text{B.st}$$

MOP\* = Maximum over pull (Single Grade only e.g. S)

Pa (S) = Maximum allowable design load in tension for Grade S, lbs

B.st. = Buoyed String Weight (Hook Load less Hook Weight), lbs

Example: Maximum allowable design load in tension for 5 inches Grade S, is 560,760 lbs., Buoyed String Weight is 229,500 lbs.

What is the Maximum over pull?

$$\text{MOP} = (560,760 \times 0.9) - 229,500$$

$$\text{MOP} = 275,184 \text{ lbs}$$

## 1. Well Control:

### **Pressure:**

$$= \text{Mud Weight, ppg} \times 0.052 \times \text{true vertical depth (TVD), ft.}$$

### **Hydrostatic pressure:**

Hydrostatic Pressure, psi =

$$\text{Mud weight, ppg} \times \text{true vertical depth (TVD), ft.} \times 0.052$$

- Hydrostatic pressure HP, using mud weight in ppg and True vertical depth in feet.

$$\text{HP} = \text{mud weight, ppg} \times 0.052 \times \text{true vertical depth (TVD), ft.}$$

Example: If the mud weight is 12.5 ppg



True vertical depth is 10,000 ft.

What is the Hydrostatic Pressure in psi?

HP = 12.5 ppg x 0.052 x 10,000 ft.

HP = 6,500 psi

- Hydrostatic pressure, psi, using pressure gradient, psi/ft.

**HP = Pressure Gradient psi/ft. x true vertical depth, ft.**

Example: If the pressure gradient is 0.619 psi/ft.

True vertical depth = 10,000 ft.

What is the Hydrostatic Pressure in psi?

Hydrostatic pressure = 0.619 psi/ft. x 10,000 ft.

Hydrostatic pressure = 619 psi

- Hydrostatic pressure, psi, using mud weight, lb/ft<sup>3</sup>

**HP = mud weight, lb/ft<sup>3</sup> x 0.006944 x TVD, ft.**

Example: mud weight is 85 lb/ft<sup>3</sup>

True vertical depth = 8,000 ft.

What is the Hydrostatic Pressure in psi?

HP = 85 lb/ft<sup>3</sup> x 0.006944 x 8000 ft.

HP = 4,721.92 psi

- Hydrostatic pressure, psi, using meters as unit of depth

**HP = mud weight, ppg x 0.052 x TVD, m x 3.281**

Example: mud weight = 10 ppg

True vertical depth = 4000 meters

What is the Hydrostatic Pressure in psi?

HP = 10 ppg x 0.052 x 4000 m x 3.281

HP = 6,824.48 psi



### Pressure gradient:

- Pressure Gradient, psi/ft., using mud weight, ppg

$$\text{Pressure Gradient, psi/ft.} = \text{Mud Weight, ppg} \times 0.052$$

Example: If the mud weight is 10.0 ppg.

What is the Pressure Gradient in psi/ft.?

$$\text{Pressure Gradient in psi/ft.} = 10.0 \text{ ppg} \times 0.052$$

$$\text{Pressure Gradient in psi/ft.} = 0.520 \text{ psi/ft.}$$

- Pressure Gradient, psi/ft., using mud weight, lb/ft<sup>3</sup>

$$\text{Pressure Gradient, psi/ft.} = \text{Mud Weight, lb/ft}^3 \times 0.006944$$

Example: If the mud weight is 100 lb/ft<sup>3</sup>.

What is the Pressure Gradient in lb/ft<sup>3</sup>?

$$\text{Pressure Gradient in lb/ft}^3 = 100 \text{ lb/ft}^3 \times 0.006944$$

$$\text{Pressure Gradient in lb/ft}^3 = 0.6944 \text{ lb/ft}^3$$

Also, could use the other formula to calculate the pressure gradient:

$$\text{Pressure Gradient, psi/ft.} = \text{Mud Weight, lb/ft}^3 \div 144$$

Example: If the mud weight is 100 lb/ft<sup>3</sup>.

What is the Pressure Gradient in lb/ft<sup>3</sup>?

$$\text{Pressure Gradient in lb/ft}^3 = 100 \text{ lb/ft}^3 \div 144$$

$$\text{Pressure Gradient in lb/ft}^3 = 0.6944 \text{ lb/ft}^3$$

- Pressure Gradient, psi/ft., using Specific Gravity SG

$$\text{Pressure gradient, psi/ft.} = \text{Mud Weight, specific gravity SG} \times 0.433$$

Example: If fluid specific gravity is 1.0.

What is the Pressure Gradient in psi/ft.?

$$\text{Pressure Gradient in psi/ft.} = 1.0 \text{ SG} \times 0.433$$

$$\text{Pressure Gradient in psi/ft.} = 0.433 \text{ psi/ft.}$$



### Specific gravity

- **Specific gravity using mud weight, ppg**

$$SG = \text{Mud Weight, ppg} \div 8.33$$

Example: If the fluid mud weight is 12 ppg

What is the Specific gravity?

$$SG = 12 \text{ ppg} \div 8.33$$

$$SG = 1.441$$

- **Specific gravity using pressure gradient, psi/ft.**

$$SG = \text{pressure gradient, psi/ft.} \div 0.433$$

Example: If the pressure gradient = 0.624 psi/ft.

What is the Specific gravity?

$$SG = 0.624 \text{ psi/ft.} \div 0.433$$

$$SG = 1.441$$

- **Specific gravity using mud weight, lb/ft<sup>3</sup>**

$$SG = \text{Mud Weight, lb/ft}^3 \div 62.4$$

Example: mud weight = 90 lb/ft<sup>3</sup>

What is the Specific gravity?

$$SG = 90 \text{ lb/ft}^3 \div 62.4$$

$$SG = 1.442$$

### Force

$$\text{Force} = \text{Pressure, psi} \times \text{Area, inches}^2$$

$$\text{Force} = \text{lbs}$$

### Length to Create a pressure, ft.

$$= \text{Pressure, psi} \div \text{pressure gradient, psi/ft.}$$

$$= \text{Pressure, psi} \div \text{Mud Weight, ppg} \div 0.052$$



### Formation Pressure.

$$= \text{Mud Weight, ppg} \times 0.052 \times (\text{Bit TVD, ft}) + \text{SIDPP, psi}$$

SIDPP = Shut In drill Pipe Pressure, psi

TVD = True Vertical Depth, feet

Fresh water (Normal) = 0.433 psi/ft x formation depth, ft

Salt water (abnormal) = 0.46 psi/ft x formation depth, ft

### Kill Mud Weight, ppg

$$= (\text{SIDPP, psi} \div 0.052 \div \text{TVD, ft}) + \text{Mud Weight, ppg}$$

Example: If Bit TVD is 10,000 ft, Mud Weight is 10.6 ppg and Shut In drill Pipe Pressure (SIDPP) is 800 psi.

What is the required Kill Mud weight?

$$\text{Kill Mud Weight, ppg} = (800 \div 0.052 \div 10,000) + 10.6 \text{ ppg}$$

$$\text{Kill Mud Weight, ppg} = 1.54 \text{ ppg} + 10.6 \text{ ppg}$$

$$\text{Kill Mud Weight, ppg} = 12.14 \text{ ppg}$$

### Initial Circulating Pressure, psi

$$\text{ICP} = (\text{SIDPP, psi}) + \text{Slow Circulating Rate Pressure, psi}$$

Example: If Slow Circulating Rate Pressure @ 40 SPM is 900 psi for the previous example.

What is the Initial Circulating Pressure, psi?

$$\text{Initial Circulating Pressure, psi} = (800) \text{ psi} + 900 \text{ psi}$$

$$\text{Initial Circulating Pressure, psi} = 1700 \text{ psi}$$

### Final Circulating Pressure, psi

$$\text{FCP} = \text{Slow Circulating Rate Pressure, psi} \times \frac{\text{Kill Mud Weight, ppg}}{\text{Old Mud Weight, ppg}}$$

Example: Same for the previous example.

What is the Final Circulating Pressure, psi?

$$\text{Final Circulating Pressure, psi} = (900) \text{ psi} \times \frac{12.4}{10.6}$$

$$\text{Final Circulating Pressure, psi} = 900 \text{ psi} \times 1.1453$$

$$\text{Final Circulating Pressure, psi} = 1031 \text{ psi}$$



### Fracture Mud Weight, ppg

$$= (\text{Leak off Test, psi} \div \text{Shoe TVD, ft} \div 0.052) + \text{Mud Weight, ppg}$$

Example: Leak off Test (LOT) was 2000 psi with 10.0 ppg mud weight in hole and the shoe TVD at 8,000 feet.

What is the Fracture Mud Weight, ppg?

$$\text{Fracture Mud Weight, ppg} = (2000 \div 8000 \div 0.052) + 10.0 \text{ ppg}$$

$$\text{Fracture Mud Weight, ppg} = 14.81 \text{ ppg}$$

### Fracture Gradient, psi/ft

$$\text{Fracture Gradient, psi/ft} = (\text{Fracture Mud Weight, ppg} \times 0.052)$$

Example: same for the previous example

What is the Fracture Gradient, psi/ft?

$$\text{Fracture Gradient, psi/ft} = (14.81 \text{ ppg} \times 0.052)$$

$$\text{Fracture Gradient, psi/ft} = 0.77 \text{ psi/ft}$$

### Fracture Pressure, psi

$$= (\text{Fracture Mud Weight, ppg} \times 0.052 \times \text{Shoe TVD, ft})$$

Example: same for the previous example

What is the Fracture Pressure, psi?

$$\text{Fracture Pressure, psi} = (14.81 \text{ ppg} \times 0.052 \times 8000 \text{ ft})$$

$$\text{Fracture Pressure, psi} = 6161 \text{ psi}$$

### Maximum Pressure Allowed on Casing Gauge during Operations

#### MAASP, psi

$$= (\text{Fracture Mud Weight, ppg} - \text{Current Mud Weight, ppg}) \times 0.052 \times \text{Shoe TVD, ft}$$

Example: Fracture Mud Weight is 14.81 ppg, Current Mud Weight is 10.6 ppg and the shoe TVD at 8,000 feet.

What is the MAASP, psi?

$$\text{MAASP, psi} = (14.81 \text{ ppg} - 10.6 \text{ ppg}) \times 0.052 \times 8000 \text{ feet}$$

$$\text{MAASP, psi} = (4.21) \times 0.052 \times 8000 \text{ feet}$$

$$\text{MAASP, psi} = 1751 \text{ psi}$$



## 1. Casing & Cementing:

### **Buoyant Force on Casing**

$$= C_1 [ (C. wt \times B.F. cmt) - (42 \times C.cap \times (W.cmt - MWt.)) ]$$

C1 = Casing Length, ft

C.wt = Casing Wt/ft, lbs/ft

C.cap = Casing Capacity, bbls/ft

W.cmt = Cement Weight, ppg

B.F.cmt = Cement Buoyancy Factor

M.Wt. = Mud Weight, ppg

Example: If Casing length is 1500 feet, Casing weight per feet is 106.5 lbs/ft, Casing capacity is 0.3507 bbls/ft, using cement weight of 15.4 ppg and Mud Weight of 9.0 ppg with 0.765 Cement Buoyancy Factor .

What is Buoyant Force on Casing, lbs?

Buoyant Force on Casing, lbs

$$= 1500 [ (106.5 \times 0.765) - (42 \times 0.3507 \times (15.4 - 9.0)) ]$$

$$= 1500 [ (81.47 - (14.73 \times 6.4)) ]$$

$$= 1500 [ (81.47 - (94.27)) ]$$

$$= 1500 [ (-12.8) ]$$

$$= -19,200 \text{ lbs}$$

(Negative means an upward force, Positive means a downward force)

### **Balance Mud Weight, ppg**

$$\text{Balance Mud Weight} = W.cmt - \frac{C.wt \times B.F.cmt}{42 \times C.cap}$$

C.wt = Casing Wt/ft, lbs/ft

C.cap = Casing Capacity, bbls/ft

W.cmt = Cement Weight, ppg

B.F.cmt = Cement Buoyancy Factor



Example: If Casing weight per foot is 106.5 lbs/ft, Casing capacity is 0.3507 bbls/ft, using cement weight of 15.4 ppg and Mud Weight of 9.0 ppg with 0.765 Cement Buoyancy Factor .

What is Balance Mud Weight, ppg?

Buoyant Force on Casing, lbs

$$= 15.4 - \left[ \frac{106.4 \times 0.765}{42 \times 0.3507} \right]$$

$$= 15.4 - \frac{81.396}{14.729}$$

$$= 15.4 - 5.5$$

$$= 9.9 \text{ ppg}$$

### Sack of Cement

$$\text{Sacks} = \frac{\text{Volume of Cement, bbls} \times 5.6146}{\text{Yield/Sack, cu.ft}}$$

Example: Volume of cement required is 500 bbls and the Yield/Sack of cement is 1.15 cu. ft/sack.

How many sacks of cement are needed?

$$\text{Sacks} = \frac{500 \times 5.6146}{1.15}$$

$$= \frac{2807.3}{1.15}$$

$$= 2441 \text{ Sacks}$$

### Balance Plugs

- **Cement Volume Required**

$$V_{\text{cm}} = \frac{\text{Hole Diameter}^2}{1029.4} \times \text{Required Plug Length, ft}$$

$$V_{\text{cm}} = \text{Hole Capacity, bbls/ft} \times \text{Required Plug Length, ft}$$

V<sub>cm</sub> = Volume of cement, bbls



- **Water Spacer Ahead, bbls**

Choose a volume but be careful that loss of hydrostatic does not cause kick.

- **Length of Spacer in Annulus, ft ( $V_1$ )**

$$V_1 = \frac{\text{Spacer Volume, bbls}}{\text{Annular Volume, bbls/ft}}$$

- **Volume of Spacer behind cement, bbls ( $V_2$ )**

$$V_2 = V_1 \times \text{Pipe Capacity, bbls/ft}$$

- **Length of Balanced cement column, ft**

$$= \frac{\text{Cement Volume, bbls}}{(\text{Annular Volume, bbls/ft} + \text{Pipe Capacity, bbls/ft})}$$

- **Mud to Displace Plug into position, bbls**

$$= [(\text{C.base} - \text{L.plug}) \times \text{Pipe Capacity, bbls/ft}] - V_2$$

C.base = Base of Plug, ft

L.plug = Length of Cement plug, ft

$V_2$  = volume of Spacer behind Cement, bbls

- **Strokes to Displace**

$$= \frac{\text{Mud to Displace, bbls}}{\text{Pump output/stroke}}$$

- **Example:**

Plug Length to be = 400 feet

Water Spacer = 20 bbls

Annular Volume = 0.1215 bbls/ft

Pipe Capacity = 0.01776 bbls/ft

Hole Capacity = 0.1458 bbls/ft

Depth of Plug base = 10,000 ft

Pump output = 0.109 bbls/stroke



### What is Cement Volume Required, bbls?

$$V_{cm} = \text{Hole Capacity, bbls/ft} \times \text{Required Plug Length, ft}$$

$$V_{cm} = 0.1458 \text{ bbls/ft} \times 400 \text{ feet}$$

$$V_{cm} = 58.32 \text{ bbls}$$

What is Length of Spacer in the Annulus, ft?

$$V_1 = \frac{\text{Spacer Volume, bbls}}{\text{Annular Volume, bbls/ft}}$$

$$V_1 = \frac{20 \text{ bbls}}{0.1215 \text{ bbls/ft}} = 164.6 \text{ ft}$$

### What is Volume of Spacer behind Cement, bbls?

$$V_2 = V_1 \times \text{Pipe Capacity, bbls/ft}$$

$$V_2 = 164.6 \text{ ft} \times 0.01776 \text{ bbls/ft}$$

$$V_2 = 2.92 \text{ bbls}$$

### What is Length of Balanced cement column, ft?

$$= \frac{\text{Cement Volume, bbls}}{(\text{Annular Volume, bbls/ft} + \text{Pipe Capacity, bbls/ft})}$$

$$= \frac{58.32 \text{ bbls}}{0.1215 \text{ bbls/ft} + 0.01776 \text{ bbls/ft}}$$

$$= \frac{(58.32 \text{ bbls})}{0.13926 \text{ bbls/ft}}$$

$$= 418.8 \text{ ft}$$

What is Mud to displace into position, bbls?

$$= [(C.\text{base} - L.\text{plug}) \times \text{Pipe Capacity, bbls/ft}] - V_2$$

$$= [(10,000 \text{ ft} - 418.8 \text{ ft}) \times 0.01776 \text{ bbls/ft}] - 2.92 \text{ bbls}$$

$$= [(9,581.2 \text{ ft}) \times 0.01776 \text{ bbls/ft}] - 2.92 \text{ bbls}$$

$$= 170.16 \text{ bbls} - 2.92 \text{ bbls}$$

$$= 167.24 \text{ bbls}$$



What is Strokes to Displace, strokes?

$$\text{Strokes to Displace, strokes} = \frac{\text{Mud to Displace, bbls}}{\text{Pump output/stroke}}$$

$$= \frac{167.24 \text{ bbls}}{0.109 \text{ bbls/strokes}}$$

$$= 1534 \text{ strokes}$$

## 1. Hydraulics:

**Annular Velocity, ft/min**

$$= \frac{24.51 \times \text{Flow Rate, GPM}}{(D_h^2 - d_p^2)}$$

$D_h$  = Hole Diameter, inches

$d_p$  = Pipe Outside Diameter, inches

Example: If the flow rate is 450 gallons per minute (GPM), Hole Diameter is 12 ¼ inches and the drill pipe outside diameter is 5 inches.

What is the Annular Velocity, ft/min?

$$= \frac{(24.51 \times 450 \text{ GPM})}{(12.25^2 - 5^2)}$$

$$= \frac{11029.5}{125.0625}$$

$$= 88.2 \text{ ft/min}$$

**Equivalent Circulating Density (ECD)**

Equivalent Circulating Density (ECD) For Low Mud Weight

$$\text{ECD} = \text{Mud Weight, ppg} + \frac{\text{Yield Point} \times 0.1}{(D_h - d_p)}$$

$D_h$  = Hole Diameter, inches

$d_p$  = Pipe Outside Diameter, inches

Example: If the Mud weight is 11 ppg, Yield Point is 13, Hole Diameter is 12 ¼ inches and the drill pipe outside diameter is 5 inches.



What is the Equivalent Circulating Density (ECD), ppg?

$$= 11 + \frac{(13 \times 0.1)}{(12.25 - 5)}$$

$$= 11 + \frac{1.3}{(12.25 - 5)}$$

$$= 11 + 0.18$$

$$= 11.18 \text{ ppg}$$

Equivalent Circulating Density (ECD) For high Mud Weight which is greater than 13 ppg.

$$\text{ECD} = \text{M. Wt, ppg} + \frac{0.1}{(D_h - d_p)} \times \left( \text{YP} + \left( \frac{\text{PV} \times V}{300 \times (D_h - d_p)} \right) \right) ]$$

$D_h$  = Hole Diameter, inches

$d_p$  = Pipe Outside Diameter, inches

M.Wt. = Mud Weight, ppg

YP = Yield Point

PV = Plastic Viscosity

V = Annular Velocity, ft/min

Example:

Hole Diameter = 12 ¼ inches

Pipe Outside Diameter = 5 inches

Mud Weight = 15 ppg

Yield Point = 18

Plastic Viscosity = 30

Annular Velocity = 90 ft/min



What is the Equivalent Circulating Density (ECD), ppg?

$$= 15 + \left[ \frac{0.1}{12.25 - 5} \times \left( 18 + \left( \frac{30 \times 90}{300 \times (12.25 - 5)} \right) \right) \right]$$

$$= 15 + \left[ \frac{0.1}{7.25} \times \left( 18 + \left( \frac{30 \times 90}{300 \times (7.25)} \right) \right) \right]$$

$$= 15 + \left[ 0.0138 \times \left( 18 + \left( \frac{2700}{2175} \right) \right) \right]$$

$$= 15 + \left[ 0.0138 \times (18 + 1.2414) \right]$$

$$= 15 + \left[ 0.0138 \times 19.2414 \right]$$

$$= 15 + 0.2655$$

$$= 15.26 \text{ ppg}$$

### **Plastic Viscosity & Yield Point**

#### **Plastic Viscosity**

Plastic Viscosity (PV) = Fann 600 reading - Fann 300 reading

- Rule of Thumb: Keep Plastic Viscosity as low as possible

#### **Yield Point**

Yield Point (YP) = Fann 300 reading - Plastic Viscosity

- Rule of Thumb: Keep Yield Point equal to Mud weight, ppg as possible

#### **Fann reading**

Fann 600 reading = 2 PV + YP

Fann 300 reading = PV + YP

#### **Apparent Viscosity**

Apparent Viscosity =  $\frac{\text{Fann 600 reading}}{2}$



## 1. Miscellaneous:

### Critical RPM

RPM to avoid due to excessive vibration

$$\text{Critical RPM} = \frac{33055}{L^2} \times \sqrt{(OD^2 - ID^2)}$$

L= Length of one joint of pipe, ft

OD= Pipe Outside Diameter, inches

ID = Pipe inside Diameter, inches

Example: If the Length of one joint of pipe is 31 feet, 5 inches drill pipe Outside Diameter and the drill pipe inside diameter is 4.276 inches.

What is Critical RPM?

$$= \frac{33055}{31^2} \times \sqrt{(5^2 - 4.276^2)}$$

$$= \frac{33055}{(961)} \times \sqrt{(43.284)}$$

$$= 34.3964 \times 6.579$$

$$= 226 \text{ RPM}$$

### **Mud Building**

**This formula to be used to weigh up mud with Barite.**

$$V_c, \text{ bbls} = V_f \times \left[ \frac{(35 - MW_f)}{(35 - MW_c)} \right]$$

V<sub>c</sub>= Initial Volume of Clay based mud, bbls

V<sub>f</sub>= Final volume of mud required, bbls

MW<sub>f</sub> = Final mud weight, ppg

MW<sub>c</sub> = Initial Clay based mud weight, ppg

MW<sub>w</sub> = weight of water, ppg

V<sub>w</sub>= Volume of starting water

**Volume of starting water**

$$V_w, \text{ bbls} = V_c \times \left[ \frac{(21.66 - MW_c)}{(21.66 - MW_w)} \right]$$

**Clay Required**

$$\text{Clay Req., lbs} = V_w \times \left[ \frac{910 (MW_c - MW_w)}{(21.66 - MW_c)} \right]$$

**Barite Required**

$$\text{Barite Req., lbs} = V_c \times \left[ \frac{1470 (MWF - MW_c)}{(35 - MWF)} \right]$$

**Volume Check**

$$\text{Vol. Check, bbls} = V_w + \left[ \frac{\text{Clay Reg.}}{910} + \frac{\text{Barite Reg.}}{1470} \right]$$

**Rule of Thumb:**

- Bentonite increases volume by approximately 1 bbl. Every 9 sacks.
  - Barite increases volume by approximately 1 bbl. Every 15 sacks
- 1 sack = 100 lbs.

Example: 500bbls. Of clay based mud weighing 9.5 ppg is required.

Weight of water = 8.4 ppg, weight of clay based mud = 8.8 ppg.

**Find volume of Clay based on mud, bbls?**

$$V_c, \text{ bbls} = V_f \times \left[ \frac{(35 - MWF)}{(35 - MW_c)} \right]$$

$$V_c = 500 \left[ \frac{(35 - MWF)}{(35 - MW_c)} \right]$$

$$= 486.6 \text{ bbls}$$

**Find Volume of starting water?**

$$V_w, \text{ bbls} = V_c \times \left[ \frac{(21.66 - MW_c)}{(21.66 - MW_w)} \right]$$

$$V_w, \text{ lbs} = 486.6 \left[ \frac{(21.66 - 8.8)}{(21.66 - 8.4)} \right]$$

$$= 472 \text{ bbls}$$



### Find Volume of Clay Required?

$$\text{Clay Req., lbs} = V_w \times \left[ \frac{910 (MWC - MWw)}{(21.66 - MWC)} \right]$$

$$\text{Clay required, lbs} = 472 \left[ \frac{910 (8.8 - 8.4)}{21.66 - 8.8} \right]$$

Clay required, lbs = 13,360 pounds

### Find Volume of Barite Required?

$$\text{Barite Req., lbs} = V_c \times \left[ \frac{1470 (MWF - MWC)}{(35 - MWF)} \right]$$

$$\text{Barite required, lbs} = 486.6 \left[ \frac{(1470 (9.5 - 8.8))}{35 - 9.5} \right]$$

Barite required, lbs = 19,636 pounds

### Find Volume check, bbls?

$$\text{Vol. Check, bbls} = V_w + \left[ \frac{\text{Clay Reg.}}{910} + \frac{\text{Barite Reg.}}{1470} \right]$$

$$\text{Volume Check, bbls} = 472 + \left( \frac{13360}{910} \right) + \left( \frac{19636}{1470} \right)$$

Volume Check, bbls = 472 + 14.7 + 13.3

Volume Check, bbls = 500 bbls

## Micron Sizes

Material		Value
Clay and Bentonite	Less than	1
Barite		2- 60
Silt		2 - 74
API Sand	Greater than	74
Talcum Powder		5 - 50
Kitchen Flour		1 - 80



## Micron cut points

Equipment		Value
Centrifuge	---	3 – 5 Micron
Desilter	3" – 4" Cones	12 – 60 Micron
Desander	5" – 12" Cones	30 – 60 Micron

## Pressure at cone manifold

### Rule of Thumb:

- Required pump pressure at cone manifold on Desilter or Desanders  
= 4 x M.Wt. (ppg)

## Cone capacities

Size	Capacity GPM/cone
4"	50 GPM/cone
6"	100 GPM/cone
8"	155 GPM/cone
10"	500 GPM/cone
12"	600 GPM/cone

## PH

Measure of effective acidity or alkalinity of mud.

PH Range is 0 – 14

PH 7 is Neutral

PH Greater than 7 is ALKALINE.

PH less than 7 is ACID.

## Marsh Funnel

Time for fresh water to drain

Marsh Funnel = 26 seconds  $\pm$  ½ second per quart

## Abnormal Formation Pressure

0.465 psi/ft or 8.9 ppg



## Fresh Water Gradient

0.433 psi/ft or 8.33 ppg

## Overburden Gradient

1.0 psi/ft or 19.3 ppg

## Maximum Allowable Mud Weight from Leak-off Test Data

Max. Mud Weight (ppg) = [(Leak off Surface Pressure, psi) / 0.052 / Casing Shoe TVD, ft]. + Mud Weight (ppg)

Example:

Leak off pressure, psi = 1000 psi

Casing shoe TVD, ft. = 5000 feet

Mud weight, ppg = 10 ppg

Maximum allowable mud weight from leak-off test, ppg

= (1000 ppg / 0.052 / 5000 feet) + 10 ppg

13.846 ppg

## Pump Output

### Triplex Pump

Pump Output (bbl/stk) = (0.000243) x (Liner Diameter, inches)<sup>2</sup> x (Stroke Length, inches)

Example:

Liner Diameter, inches = 6

Stroke Length, inches = 12

Pump Efficiency = 100%

Pump Output (bbl/stk) = (0.000243) x (6)<sup>2</sup> x (12)

= 0.104976 bbl/stk @ 100% efficiency

- If Pump efficiency is not 100%, for example 90%

= 0.104976 bbl/stk x 0.90 = 0.0944784 bbl/stk @ 90% efficiency



# 19. Completion & Production

After drilling operations and casing of the well, the well can be evaluated and run Logs to start the completion operations. Completion is preparation process for a well to start production oil or gas.

If the well does not contain hydrocarbons or it is not economically worth the completion and production expenses, then the well will be plugged and abandoned.

There are different types of well completion such as cased-hole completion, open-hole completion and multi zone completion.

## 1. Cased hole completion

In a cased-hole completion, it involves running casing or a liner down through the production zone, and cementing it in place. Small holes are made in the casing to allow a flow between the well bore and the formation.

These small holes are called perforations. The number of holes is ranging from four to twelve holes per foot in the pay zone.

The perforations are made in the section of the casing which passed through the production zone. These perforations are made to provide a path for the oil to flow from the surrounding rock into the production tubing. (Fig. 20.1)

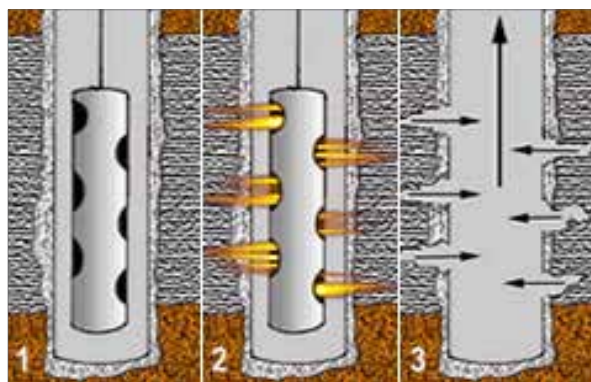

Fig 20.1- Cased-hole perforation



## 2. Open hole completion

In open-hole completion, there is no casing or liner run through the production zone. Open-hole completions can be used in wells where only one reservoir is to be produced, and the formation is hard and unlikely to collapse.

This type of completion is used in shallow wells and in wells drilled in hard rock formations, such as chalk or limestone.

Open-hole completion is inexpensive and usually far less expensive than cased-hole completions.

In open-hole completion usually sand screens or a gravel pack is installed in the last drilled, uncased reservoir section.

Open-hole completion is not suitable for unconsolidated rocks because sand particles can cause erosion of the production facilities, washouts and other problems.

Open hole completions is improving more and more every day due to the developments in the industry, and this technique is very common in horizontal wells, where cemented installations are more expensive and technically more difficult.

There are different types of Open-hole completions such as pre drilled/holed liner, slotted liner and sand control (Gravel Pack, expandable screens).

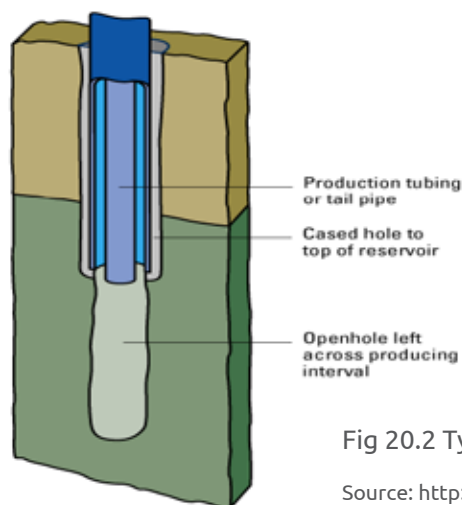

Fig 20.2 Types of well completion

Source: <http://www.glossary.oilfield.slb.com/files/OGL00032.gif>



## Comparison of Completions

Completion Type	Advantages	Disadvantages
Cased Hole	<ul style="list-style-type: none"><li>- Wellbore stability</li><li>- Isolation of zones</li><li>- Pressure control</li><li>- Control stimulation</li></ul>	<ul style="list-style-type: none"><li>- Expensive</li><li>- Limited communication to reservoir.</li><li>- Possible Cement damage.</li></ul>
Open Hole	<ul style="list-style-type: none"><li>- Maximum flow area.</li><li>- Minimize damages.</li></ul>	<ul style="list-style-type: none"><li>- Hole collapse in weak formation.</li><li>- No flow control.</li><li>- Limited or no control simulation.</li></ul>

### 1. Multi zone well completion

When a well penetrates more than one productive layer multi zone well completion is done to produce from different layers. Multi zone completion can be either single well completion or dual well completion depend on the number of producing layers.

Single well completion uses single production tubing, whereas Dual well completion uses two sets of production tubing.

After completion and perforation is done and established a flow, acids and fracturing fluids can be pumped into the well to enhance the flow and clean the well to get the maximum possible flow rate of hydrocarbons.

### Perforation

Perforation is the process of piercing the casing wall and the cement behind it to provide communication with the reservoir and enable the formation fluid to flow into the wellbore.



Fig 20.3- Perforated Casing



Perforations are made by firing gun which is called perforating guns. They can be run into the well to the desired depth on an electric wire line or transported on the bottom of the tubing.

Once the gun has fired, it is retrieved from the well by reeling in electric line but if it was conveyed on the tubing, it can be retrieved by pulling the tubing out or releasing it to fall to the unused portion of the well at the bottom which is known as the Rathole.

## Common Types of Completion Equipment:

- Wellhead
- Tubing
- Packers
- Bridge Plugs
- Seating Nipples

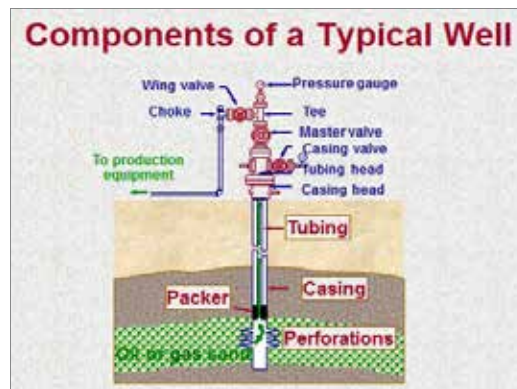

Fig 20.4 - Typical well components

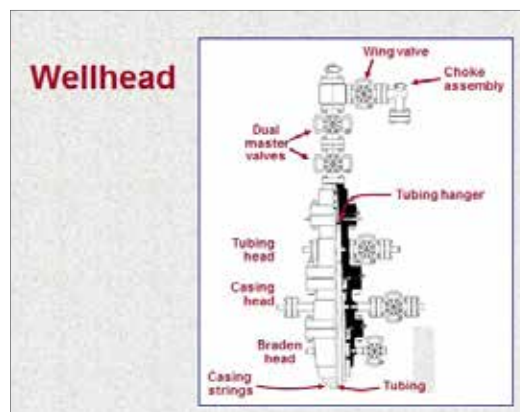

Fig 20.5- Wellhead components



Finally the tubing is run from pay zone to surface. The well fluids flow from the reservoir to the surface through the tubing. Tubing is smaller in diameter than casing.

A subsurface safety valve is installed in the tubing string near the surface. The valve remains open as long as fluid flow is normal. But when the valve reacts to sudden pressure changes with the surface equipment of the well, it closes, preventing the flow of fluids.

For each production zone, packers are used to isolate two or more production zones from each other. This is done to avoid mixing different types of fluid together and to have a better understanding/control of the flow behaviour. In addition to that, a decision can then be made whether to produce from the tubing or casing annuli or both.

Packers provide seal in well to isolate formation for production or stimulation. There are different types of packers such as permanent and retrievable.

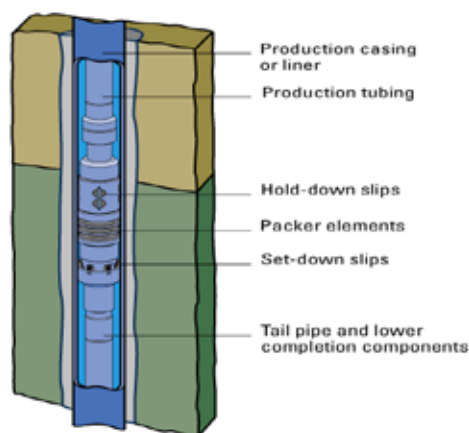

Fig 20.6 Completion components

Source: <http://www.glossary.oilfield.slb.co>

After perforation, the well is tested to determine the rate and pressure at which the hydrocarbons can be produced at the service. Also, to determine if well stimulation is needed to enhance the flow rate and the pressure.

## Well Stimulation

Well stimulation is a well intervention method that is performed on an oil or gas well to increase production by improving the well productivity.

There are different types of well intervention such as Coil Tubing, Pumping, Slickline, Wireline, Wellhead maintenance etc...and Well stimulation lies under the Pumping category.

There are methods to increase the permeability by pumping chemicals from surface to dissolve any materials that block the pores in the formations. Usually they use concentrated formic acid to clean up any mud and skin damage. This process is called acidizing. Different acids are used: HF, HCl in different concentrations depending on the formation type and targeted enhancements.



In many cases the perforation provides only limited flow and low permeability, and requires provide more surface area to increase the flow. Hydraulic fracture treatment can be carried out through the perforations to increase the surface area and increase the flow.

Hydraulic fracturing can be done by injecting high pressure fluids (greater than formation fracture pressure) into the wellbore and into the perforation tunnels to cause the rock formation to fracture. This can either be done by injecting hydraulic fluid from surface, a process called hydraulic fracturing or using an explosive to generate a high speed gas flow, a process called propellant stimulation.

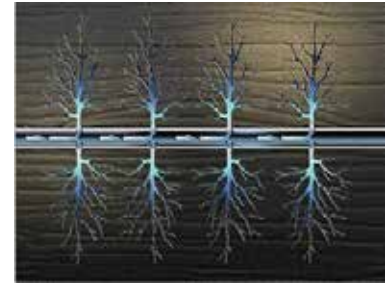

Fig 20.7 Hydraulic fracturing

Source: fracfocus.org

Oil production classified as follows:

1. Primary recovery: natural flow and artificial lift
2. Secondary recovery: such as water flooding
3. Tertiary recovery (EOR)

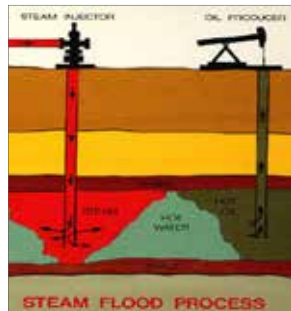

Fig 20.8 Pump on an oil well

Source: encapgroup.com

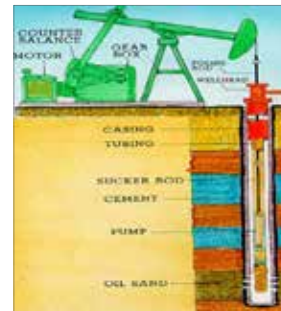

Fig 20.9 Enhanced oil recovery

Source: en.citizendium.org

Gas lift is an artificial lift method, used to lower the hydrostatic column density, therefore increase the production => increase the recovery.

Gas lift and Enhanced oil recovery are other methods which can be used to increase the flow of the reservoir.

The benefits of Well Stimulation:

- Increase production efficiency or flow capacity
- Overcome formation damage
- Enhance production from low permeability wells
- Connect with natural fracture system
- Increase effective drainage area
- Produce complex reservoirs (e.g., discontinuous sand bars)
- Increase wellbore stability (minimize drawdown)



## What Is EOR, and How Does It Work?

Oil production is separated into three phases: primary, secondary and tertiary, which is also known as Enhanced Oil Recovery (EOR). Primary oil recovery is limited to hydrocarbons that naturally rise to the surface, or those that use artificial lift devices, such as pump jacks. Secondary recovery employs water and gas injection, displacing the oil and driving it to the surface. According to the US Department of Energy, utilizing these two methods of production can leave up to 75% of the oil in the well.

The way to further increase oil production is through the tertiary recovery method or EOR. Although more expensive to employ on a field, EOR can increase production from a well to up to 75% recovery.

Used in fields that exhibit heavy oil, poor permeability and irregular fault lines, EOR entails changing the actual properties of the hydrocarbons, which further distinguishes this phase of recovery from the secondary recovery method. While water flooding and gas injection during the secondary recovery method are used to push the oil through the well, EOR applies steam or gas to change the makeup of the reservoir.

Whether it is used after both primary and secondary recovery have been exhausted or at the initial stage of production, EOR restores formation pressure and enhances oil displacement in the reservoir.

There are three main types of EOR, including chemical flooding, gas injection and thermal recovery. Increasing the cost of development alongside the hydrocarbons brought to the surface, producers do not use EOR on all wells and reservoirs. The economics of the development equation must make sense. Therefore, each field must be heavily evaluated to determine which type of EOR will work best on the reservoir. This is done through reservoir characterization, screening, scoping, and reservoir modeling and simulation.

## Thermal Recovery

Thermal recovery introduces heat to the reservoir to reduce the viscosity of the oil. Many times, steam is applied to the reservoir, thinning the oil and enhancing its ability to flow. First applied in Venezuela in the 1960s, thermal recovery now accounts for more than 50% of applied EOR in the US.

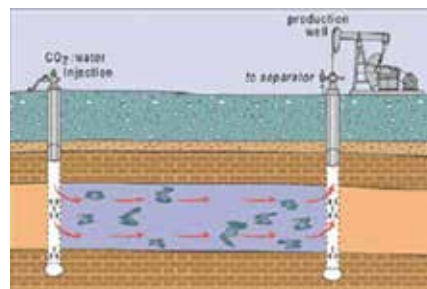

Enhanced Oil Recovery Source: Schlumberger

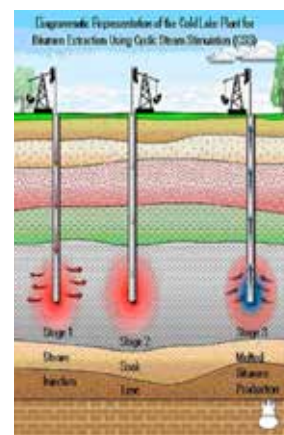

Thermal Recovery Source: Alberta Geological Survey



## Chemical Injection

Chemical injection EOR helps to free trapped oil within the reservoir. This method introduces long-chained molecules called polymers into the reservoir to increase the efficiency of water flooding or to boost the effectiveness of surfactants, which are cleansers that help lower surface tension that inhibits the flow of oil through the reservoir. Less than 1% of all EOR methods presently utilized in the US consist of chemical injections.

## Gas Injection

Gas injection used as a tertiary method of recovery involves injecting natural gas, nitrogen or carbon dioxide into the reservoir. The gases can either expand and push gases through the reservoir, or mix with or dissolve within the oil, decreasing viscosity and increasing flow.

Carbon dioxide EOR (CO<sub>2</sub>-EOR) is the method that is gaining the most popularity. While initial CO<sub>2</sub>-EOR developments used naturally occurring carbon dioxide deposits, technologies have been developed to inject CO<sub>2</sub> created as byproducts from industrial purposes.

First employed in the US in the early 1970s in Texas, CO<sub>2</sub>-EOR is successfully used in Texas and New Mexico and is expected to become more widely spread in the future. Nearly half of the EOR employed in the US is a form of gas injection.

Other EOR applications gaining acceptance are low-salinity water flooding, which is expected to increase production by nearly 20%, and well stimulation, which is a relatively low-cost solution because it can be employed to single wells (rather than the whole reservoir).

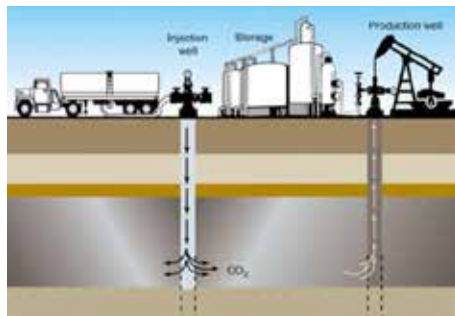

Carbon Dioxide EOR Source: Lawrence Livermore National Laboratory



## Production

The last step in completing a well is to install a wellhead at the surface of the well. Many times it is called a production tree or Christmas tree. The Christmas tree consists of casing heads and a tubing head combined to provide surface control of the subsurface conditions of the well. The tubing head supports the tubing string, seals off pressure between the casing and the inside of tubing and provides connections at the surface to control the flowing liquid or gas.

Christmas tree is equipped with a group of valves and fittings. These valves and fittings are used to regulate, measure, and direct the flow of hydrocarbons from the well. (Fig. 20.9)

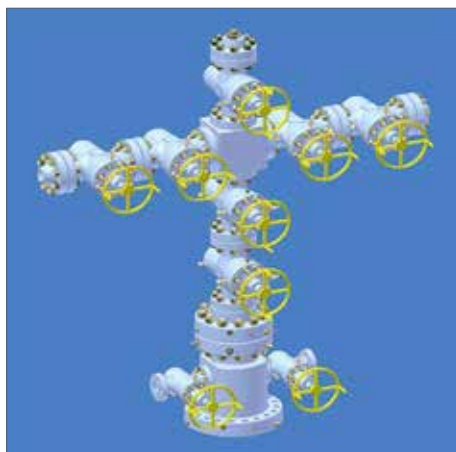

Figure 20.9 Christmas tree

Gauges measure pressure in the casing and in the tubing. Valves control the flow of hydrocarbons from the well. The choke controls the rate of production from the well. The flow is produced from the outlet valve of the production tree.

The flow can be connected to a distribution network of pipelines to Gathering Centres and further to tanks and finally supply the refineries, natural gas compressor stations, or oil export terminals.



The most important to maintain the production is to maintain the pressure of the reservoir. If the pressure depletes and it is considered economically unviable, an artificial lift method mentioned in the completions section can be employed.

## Types of Petroleum

Oil types vary in grade, density, viscosity, specific gravity, quality and selling price.

Light Crude oil is liquid petroleum that has:

- Low density.
- High permeability, flows freely at room temperature.
- Low viscosity.
- Low specific gravity.
- High API gravity due to the presence of a high proportion of light hydrocarbon fractions.
- Low wax content as well.
- High selling price.

Heavy crude oil or extra heavy crude oil that has:

- Low permeability does not flow easily.
- High density.
- High specific gravity
- API gravity less than 20°.
- Low selling price.



Note: Extra heavy oil is defined with API gravity below 10.0 °API.

API gravity is a measure of how heavy or light petroleum liquid is compared to water. If its API gravity is greater than 10, it is lighter and floats on water; if less than 10, it is heavier and sinks.

Light crude oil receives a higher price than heavy crude oil on commodity market because it produces a higher percentage of gasoline and diesel fuel when converted into products by an oil refinery.

Heavy crude oil has more negative impact on the environment than light crude oil because its refinement requires the use of more advanced techniques and the use of contaminants.

The sweet light crude oil Western Texas Intermediate (WTI) is used as a benchmark in oil pricing.

### Light Oil



Less Quality & Less Selling Price

Figure 20.12 Oil Types

Sweet Crude Oil is considered sweet if it contains less than 42% Sulfur, otherwise it is considered as Sour Crude oil (Higher than 42% of Sulfur).

## Abandonment

The well is abandoned when the well reaches an economical limit where the production rate does not give profit and the operating cost is more than the revenue.

The abandonment process start with removing the tubing from the well, then sections of well bore are filled with cement to isolate the flow path between gas and water zones from each other, as well as the surface. Completely filling the well bore with cement is costly and unnecessary. The surface around the wellhead is then excavated, and the wellhead and casing are cut off, a cap is welded in place and then buried.



## 20. Refinery & Petroleum Products

The refineries are important in getting the benefit of the hard work done previously to produce the hydrocarbons because the hydrocarbons value comes from processing and refining the crude oil to more useful petroleum products such as naphtha, gasoline, diesel fuel, asphalt base, heating oil, kerosene, and liquefied petroleum gas.

The crude oil processed in the refineries depending on a process called Separation by distillation.

There are several types of the separation by distillation such as:

- Crude Oil Distillation
- Atmospheric Distillation
- Vacuum Distillation

An oil refinery is considered as an essential part of the downstream side of the petroleum industry. (Fig 21.1)



Figure 21.1 Crude Oil refineries

Source: <http://www.arabianoilandgas.com/pictures/gallery/Kuwait-refinery.jpg>

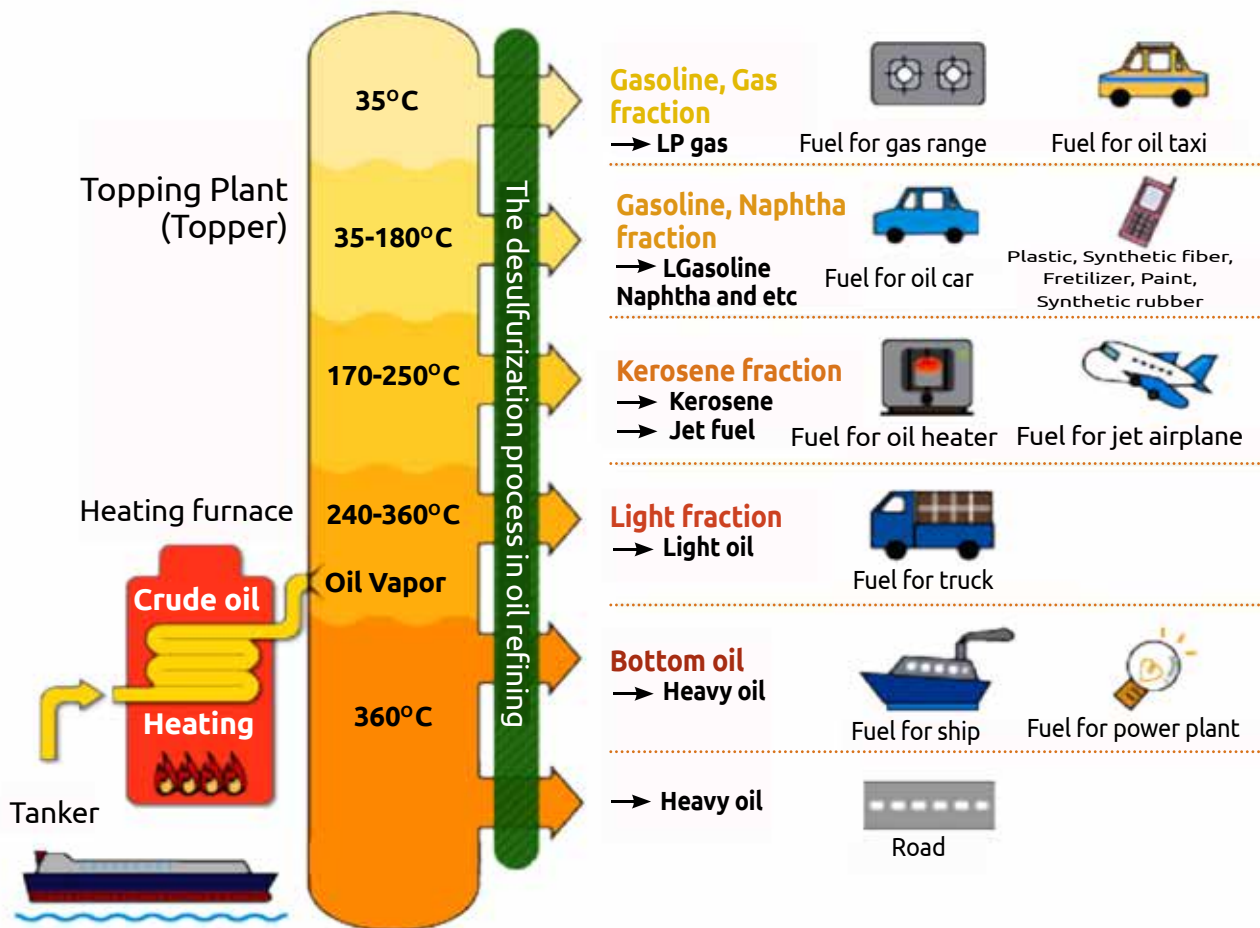

Figure 21.2 Crude Oil Separations

Source: [http://tiptonceram.com/oil\\_refining/image/img\\_sc01\\_1.gif](http://tiptonceram.com/oil_refining/image/img_sc01_1.gif)



The main objective of the crude oil distillation process is to obtain valuable petroleum products. These products have to meet certain specifications to be able to use. (Fig. 22.1)

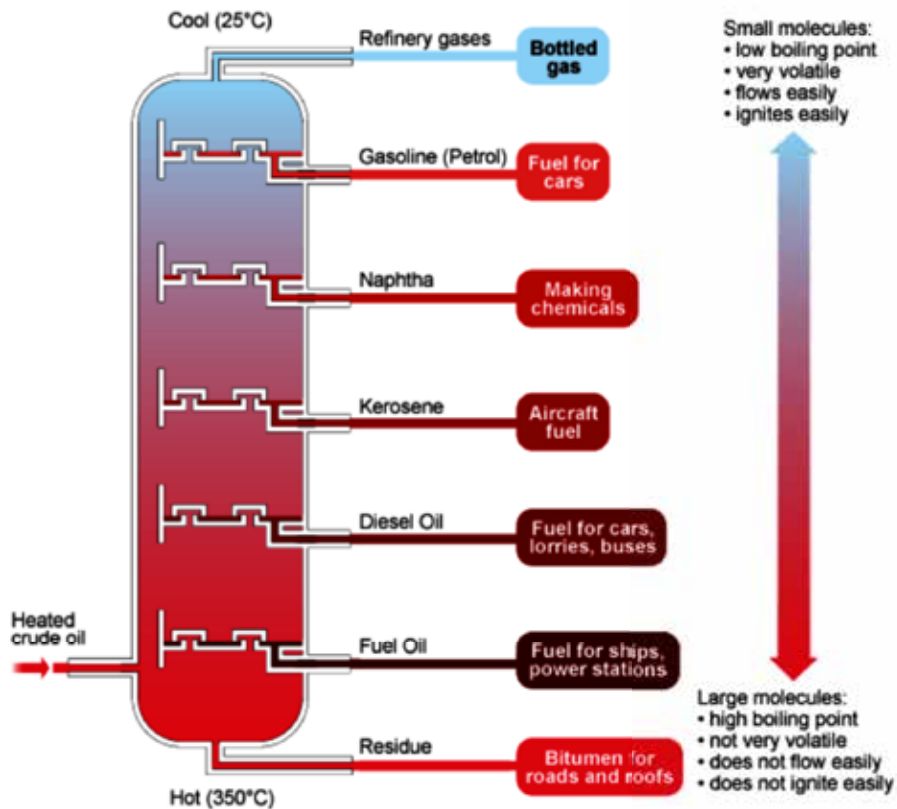

Fig 22.1 Petroleum Products

Source: <http://www.bbc.co.uk/schools/>



There are lots of valuable petroleum products such as the following:

- **Liquefied Petroleum Gas (LPG)**

LPG is a mixture of Propane and Butane; it is a flammable mixture of hydrocarbons gases used in heating appliances and some vehicles.



Fig 22.3 LP cylinders

Source: <http://upload.wikimedia.org/wikipedia/commons>

- **Naphtha**

Naphtha is a flammable liquid consists of mixtures of hydrocarbons. Naphtha is a colorless to reddish-brown volatile aromatic liquid, very similar to gasoline. It is used in many industrial and domestic uses.

Naphtha can be obtained directly from distillation of crude oil.



Fig 22.7 Naphtha

Source: <http://image.made-in-china.com/>



- **Kerosene**

Kerosene can be obtained directly from distillation of crude oil. Kerosene is thin and clear liquid formed from hydrocarbons. It is mainly used for heating; but it can be used in specialized engines for cars.



Fig 22.8 Kerosene

Source: <http://www.caltex.com/uploads/cmsne>

- **Diesel**

Diesel is used in diesel internal combustion engines, where the fuel mixture is ignited spontaneously under high pressure instead of from sparks as in gasoline engines. Diesel-powered cars generally have a better fuel economy than equivalent gasoline engines but produce less clean gas.



Fig 22.5 Diesel Fuel

Source: <http://www.dieselsnow.com/images>



- **Petroleum Coke**

Petroleum Coke can be obtained from residue of refining crude oil. It is used in manufacturing graphite, extraction of aluminum, in mining and others.



Source <http://4.bp.blogspot.com>

Fig 22.14 Petroleum Coke

- **Sulfur**

Recovered elemental sulfur is a non discretionary byproduct from petroleum refining, natural gas processing and coking plants. It is produced primarily to comply with environmental regulations that were applicable directly to emissions from the processing facility or indirectly by restricting the sulfur content of the fuels sold or used by the facility.



Source: <http://www.lions-industries.com>

Fig 22.14: Sulfur



# 21. Petrochemical Products

Petrochemicals are products derived from petroleum. Petrochemicals account for approximately 6% of total global crude oil use. Few commonly used products are:

- **Lubricating Oil**

Lubricating oils can be obtained by the treatment of distillation residue. The main function of the Lubricating oil is to reduce the friction between moving parts of machinery, equipment and engines.

The benefit of reducing the friction is to reduce heat generation and to reduce the particles wear as well as improved efficiency.



Source: <http://www.spectroinc.com/Collateral/Images/English-US/oil>

Fig 22.9 Lubricating oil



Source: <http://www.gssindustrialexpert.com/images/1169643007.jpg>

- **Grease**

Grease is lubricating oil mixed with soaps to make semisolid coherent, more resistant to oxidation and high viscosity.



Source: <http://www.honda-cs1.com/images/news/TCL-Grease-No2-2.jpg>

Fig 22.10 Grease



- **Wax**

Wax can be obtained from paraffinic oil by vacuum distillation process. It has low melting point and it is used as petroleum jelly in pharmaceutical, rubber and textiles industries and also in electrical appliances.



Source: <http://www.wax101.com/UserFiles/>  
Fig 22.11 Wax

- **Asphalt**

Asphalt is also known as bitumen, is the sticky, black and highly viscous liquid or semi-solid present in most crude petroleum. The primary use of asphalt is in road construction. It is also uses as waterproofing products for roofs.



Source: [http://upload.wikimedia.org/wikipedia/commons/thumb/4/45/Refined\\_bitumen.](http://upload.wikimedia.org/wikipedia/commons/thumb/4/45/Refined_bitumen.)  
Fig 22.12 Asphalt



<http://users.atw.hu/bekessamson/2011/02/21/ut.jpg>  
Fig 22.13 Asphalt used for roads



## Classification

Petrochemicals are produced from processing of LPG, Naphtha, AGO and Gas.

The most basic petrochemicals are considered the building blocks for organic chemistry. The basic petrochemicals are:

- Ethylene
- Propylene
- Butadiene
- Benzene
- Xylene

From these basic petrochemicals we produce a very large number of other chemicals, which are called, "petrochemical derivatives". Some examples of common petrochemicals derivatives are :

- Polyethylene, PVC, Ethylene glycols
- Polypropylene,
- Paraxylene, Benzene, Styrene, PET, Polystyrene

### ▪ Olefins

- **Ethylene and ethylene derivatives:** The most important basic petrochemical compound is Ethylene. Ethylene is widely used in the petrochemical industries. Ethylene is colorless flammable gas. It is used in agriculture to force the ripening of fruits produce. It is used in manufacturing many derivative products which are then used to manufacture packaging materials, household goods, automotive products and many more.

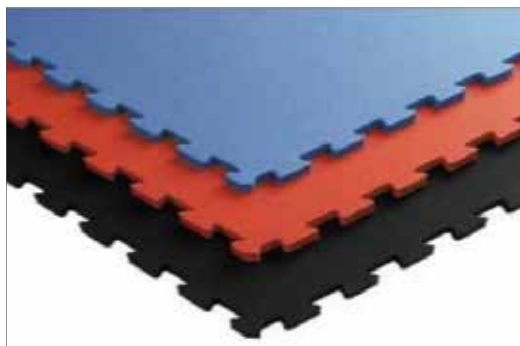

Source: <http://wholesalekarate.net/photos/cache>

Fig 22.18 Ethylene Product



- **Polyethylene:** It is the most common plastic, used in production of packaging bags and household appliances, plastic plates, spoons and forks, containers, bottles etc. The most important polyethylene grades are HDPE, LLDPE, and LDPE.



Source: [http://www.wired.com/images\\_blogs/thisdayintech](http://www.wired.com/images_blogs/thisdayintech)

Fig 22.19 Polyethylene Product

- **Poly vinyl Chloride (PVC):** PVC is a white brittle solid used to manufacture bottles, doors, windows, flexible strips, children's toys, shoes, bottles and non-food packaging.



Source: <http://in.all.biz/img/in/catalog/451930.jpeg>

Fig 22.20 Polyethylene Product



- **Ethylene Glycol:** It is mainly used for two purposes, as a raw material in the manufacture of polyester fibers, polyester chips and for antifreeze formulations.



Source: <http://www.bing.com/images>

Fig 22.21 Ethylene Glycol

- **Propylene and Propylene Derivatives:** Polypropylene is the most common derivative of propylene. Other uses for propylene are in manufacture of acrylonitrile, Acrylics etc. which are used to produce paints, solvents, acrylic fibers and yarns for textile industries.

**Polypropylene** is a thermoplastic polymer used in a wide variety of applications including packaging and labeling, textiles, ropes, carpet liners, automotive components and polymer banknotes. Polypropylene is the world's second-most widely produced synthetic plastic, after polyethylene.



Source: <http://www.fluoron.com/>  
Fig 22.22 Propylene Product



- **Butadiene and Butadiene Derivatives:** They are used in the production of synthetic rubber and plastic materials.



Source: <http://i01.i.aliimg.com/img/company>

Fig 22.23 Butadiene Product

- **Aromatics**

The main aromatics chemicals are Benzene, Toluene and the Xylenes. Aromatics are used to produce lots of products such as polyester resins used in the spinning and weaving industry and for PET bottles. It is also used in fiberglass products such as water tanks, and car parts.



[http://www.watertanks.cc/Upload/Resim/fiberglass\\_water\\_tanks\\_1.jpg](http://www.watertanks.cc/Upload/Resim/fiberglass_water_tanks_1.jpg)

Fig 22.24 Fiber Glass



- **Benzene:** It is used as a solvent and in the manufacture of Ethyl Benzene and Styrene.
- **Toluene :** It is used for manufacturing of explosives and as gasoline octane enhancer.
- **Paraxylene :** PX is the largest volume isomer of the mixed xylenes. Around 98% of PX is consumed in the polyester chain, mainly in the production of fibre, film and polyethylene terephthalate (PET) bottle resins, via one of two intermediates – purified terephthalic acid (PTA) or dimethyl terephthalate (DMT).

Benzene and Paraxylene are widely used in manufacture of other derivatives that are used to manufacture products for our daily use.

- **Styrene:** Styrene, also known as ethylbenzene, is derivative of benzene. Styrene is the precursor to polystyrene, SBR and several copolymers.
- **PET:** Polyethylene terephthalate is the most common polymer resin of the polyester family and is used in fibers for clothing, containers for liquids and foods and in combination with glass fiber for engineering resins. The majority of the world's PET production is for synthetic fibers (in excess of 60%), with bottle production accounting for about 30% of global demand.
- **Polystyrene:** Polystyrene (PS) is a synthetic polymer made from styrene. Polystyrene is used in protective packaging (such as CD and DVD cases), containers, lids, bottles, trays, tumblers, and disposable cutlery.



- **Alcohols**

There are two main products: Methanol and Ethanol.

- **Methanol:** It is used in many medical products and in different laboratories.



Source: <http://www.azmeco.com/photos/Metanol-2.jpg>

Fig 22.25 Methanol Product

- **Ethanol:** It is used as solvent in manufacturing medicines, perfumes, paints, detergents, acid anhydride and many more.



Source: <http://zedomax.com/blog/wp-content/uploads/2009/12/laundry-detergent.jpg>

Fig 22.26 Ethanol Product



## 22. Transport & Export

Crude oil must be moved from the production site to refineries and from refineries to consumers. These movements are made using five different modes of transportation such as tanker ship, pipelines, tank truck, railcar tanker and aircraft tanker.

Crude oil and refined products are transported across the water in tanker ship or barges. These tankers vary in size depend on what it carries, the smallest tankers used to transport refined products, whereas the large tankers used to transport crude oil.



Fig 23.1 Tankers



On land crude oil and products are moved using pipelines, trucks, and trains. Pipelines are the most efficient method to transport crude oil and refined products.

Pipelines are used to move crude oil from the wellhead to gathering and processing facilities and from there to refineries and tanker loading facilities. Pipelines can also be used to transport refined products such as gasoline, jet fuel, and diesel fuel from the refinery to local distribution facilities.



Fig 23.2 Pipelines

Source: <http://oil.chzhi.com/upload/12/03/22/20120322113846.jpg>

Oil wells in an area are connected to nearby gathering stations to collect the productions of these wells. Gathering stations act as collection points and delivery points for the nearby oil wells (Fig. 23.3).

Gathering station consists of pipelines to move oil from the wellhead to storage tanks and treatment facilities where the oil is measured and tested. From the gathering station the crude oil is sent to a pump station where the oil delivered to the pipeline.



Fig 23.3 Gathering Station

Source: <http://www.cpecc.cnpc.com.cn/cpecc>



Along the pipelines a Booster pumps is installed to maintain the pressure and to keep the oil flowing (Fig 23.4).The crude oil transported to huge tank farm to store it in large quantities (Fig 23.5).



Fig 23.4 Booster pumps

Source: <http://www.arabianoilandgas.com/pictures/gallery/Onshore/Pipeline3.jpg>



Fig 23.5 Tank Farm

Source: <http://www.watertubeboiler.org/2011/06/oil-tanks.jpg>

From the tank farm the crude oil could be transported to either refineries, where the oil is processed into products, or the crude oil can be transported to shipping terminals, where the oil is loaded onto tankers. (Fig 23.6-7)

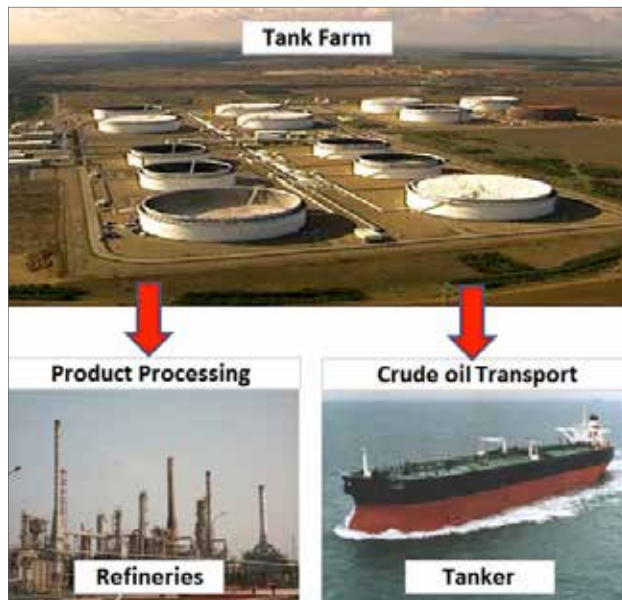

Fig 23.6 Transport path of oil from Tank farm  
[http://farm1.staticflickr.com/126/371194468\\_5336399857\\_z.jpg](http://farm1.staticflickr.com/126/371194468_5336399857_z.jpg)



Fig 23.7 Refineries Oil path

Crude oil and products can be transported by air using aircraft tanker.



## 23. Health, Safety and Environment

Health, Safety and Environment must be given first priority in all the activities we do. It is important to work safely for the protection of ourselves as well as others. We must not forget that our family and the people who love and care for us are eagerly waiting to see us return from work.

HSE is the responsibility of every individual. HSE always starts with the employee himself.

Organizations work hard and invest lots of money to promote HSE and mitigate risks as much as possible. The employee and the organization want to have accident free work place.

Health, Safety and Environment (HSE) helps to protect or at least minimize the impact due to any event that might cause harm to people, health and the environment.



The oilfield business is considered as one of the hazardous businesses in the world besides coal mining.

Human beings are risk takers. The way individual curiosity and trying to do things differently mark human beings different from all other animal. All along the work or activity, every individual learn to do things in a better manner. Practice makes a man perfect. However, it is necessary to understand



by everyone that his actions should not harm him, others, or the environment in any way. From top management through to entry level, everyone is responsible and accountable for Health, Safety and Environment.

Therefore, the goal of the organization is to protect their people, the public, their property and the environment in which individuals work and live. The leadership through policies declares its commitment to carryout business in the best interest of their customers, employees and all other stakeholders.

It is possible to run all operations without injuries or damage to equipment or the environment. This requires a methodical approach to understanding the business, the local and international rules and with all this build a set of business rules or procedures known as “HSE Management System”.

Health, Safety and Environmental (HSE) Management is an integral and an essential part of the way we do our business. It is considered as an equal part of the wider system for the management of our business. Each person involved in any activity within the business framework has to consider the risk involved to the safety of the personnel, the environmental impact and the health risk in long term.

HSE Management system aids in providing every employee to make safety on-the-job and off the job an everyday priority by emphasizing Key principles such as Participation, Accountability, consistency, Communication and Training. Oil & Gas industries are aiming to achieve incident free operations, which requires an attitude - an attitude that says any injury or incident, even a small one, should not be taken lightly and it is achieved through effective employee training and awareness programs.

It is in best interest of the business to promote an atmosphere to grow employee learning and opportunity in a way that is fulfilling, recognized and fairly rewarded. Hence, the HSE Management System is designed for ever evolving, i.e. it keeps changing for the betterment of the business. Each individual in the organization has to contribute to this change so that it reflects to build a robust system.

The HSE Management System defines the elements by which we will conduct our operations. The HSE Management System model is comprised of several interrelated elements with underlying expectations.



## Benefits of HSE Management Systems

There are several benefits of HSE Management system for safer operations of Oil & Gas industries such as:

- It enables Oil and Gas industry in performing hazard identification, risk assessment and implementing various control methods
- It ensures well-being of all the employees and thus contributes to a more inspired, and performance driven workforce
- Regular risk assessment process helps in frequent tracking and monitoring of health and safety indicators (both leading and lagging).
- Reduced costs associated with accidents and incidents
- Improved regulatory compliance to local, regional and international requirements.
- Implementation of HSE management system gives competitive edge and improves relationships between stakeholders, such as clients, contractors, subcontractors, consultants, suppliers, employees and unions.

Given the hazardous nature of the Oil and Gas industry, the need for implementation of an efficient Health, Safety and Environment is necessary.

Management System is important for improving safety and health performance. HSEMS not only provides a systematic and synchronized proactive approach to managing environmental aspects, occupational health and safety risks, but also helps in defining strategies for implementing control actions, performance substantiation, resource mapping and competency management. Moreover, it also helps in enhancing organization's brand image in today's competitive scenario. Please ensure to refer to respective company HSE Management System and adhere to guidelines for protecting employees, property and the environment.



## The leadership Management:

- Set a personal example day to day by following HSE rules.
- Make decisions that consider HSE matters equal to cost, quality, morale and production.
- Delegate the necessary authority to the appropriate personnel and allocate resources to carry out HSE functions.
- Visit operations on a regular basis through leadership visit to demonstrate commitment and recognize performance in HSE matters.
- Hold those in positions of authority accountable at all levels of the company for compliance with company policies and global standards.
- Develop HSE objectives at your level of responsibility.
- Communicate with employees, clients, subcontractors and industry personnel so that they know and understand the intent of HSE policies.
- Celebrate and promote your HSE success.

## EMPLOYEE'S RIGHTS

Many hazards found on oil and gas operations are common to virtually all workplaces. Recognizing hazards is the first step in protecting employees on oil and gas operations. Every employee has a significant role to play in recognizing hazards and mitigation of its impacts. Knowing employee rights in safer operations is important which are as follows:

### **You have a Right to:**

- Know about hazardous materials and /or dangerous machinery in your workplace.
- Be aware of how these hazards can affect you and your co-workers.
- Get required HSE training, including learning how to identify workplace hazards and knowing the proper course of action when there is an accident.
- Learn who you can get help from if you have questions related to HSE issues of your work site.

### **You have a Right to Participate:**

- In identifying hazards present on your worksite.
- In reporting any unsafe practices or conditions you observe.
- In educating your co-workers about HSE procedures.
- In conducting Job Safety Analysis prior to the work and reviewing the control measures to minimize the risk.



## Right to Refuse /STOP Unsafe Work:

- You have the right to refuse / participate in unsafe work.
- If you think that the work you / co-employee do or the piece of equipment you /other employee use are unsafe, you can ask for Time out for Safety (TOFS) to rectify and ensure safe conditions.
- Contact your immediate Supervisor or HSE representative to find out how to correct the unsafe conditions.
- Please do not continue to work until you have been advised that the situation have been corrected.

Each employee is responsible for his own Safety and ensure his Co-workers Safety. Every employee should report unsafe working conditions, not interfere in the work of others, not allow others to interfere in his work.

Generally, oil & gas companies are implementing HSE Management System in line with ISO 14001: 2015 (Environmental Management System) and OHSAS 18001:2008 (Occupational Health Assessment Series Standard).

## ISO 14001: 2015 Standard

ISO 14001:2015 sets out the criteria for an environmental management system and can be certified to any type of industry including Oil & Gas Industries. It maps out a framework that a company or organization can follow to set up an effective environmental management system. It can be used by any organization regardless of its activity or sector. ISO 14001 helps organizations improve their environmental performance through more efficient use of resources and reduction of waste, gaining a competitive advantage and the trust of all stakeholders.

The basis for the approach underlying an environmental management system is founded on the concept of Plan-Do-Check-Act (PDCA). The PDCA model provides an iterative process used by organizations to achieve continual improvement. It can be applied to an environmental management system and to each of its individual elements as below:

- Plan: establish environmental objectives and processes necessary to deliver results in accordance with the organization's environmental policy.
- Do: implement the processes as planned.
- Check: monitor and measure processes against the environmental policy, including its commitments, environmental objectives and operating criteria, and report the results.
- Act: take actions to continually improve.



The following diagram shows how the framework introduced in this International Standard by integrating into a PDCA model:

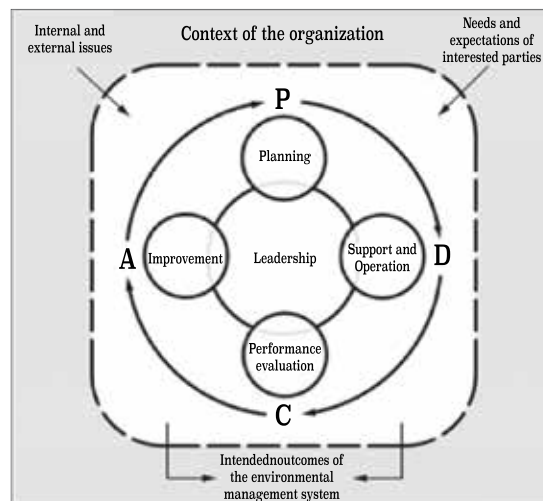

## OHSAS (Occupational Health and Safety Assessment Series) 18001

OHSAS 18001, Occupational Health and Safety Assessment Series, (officially BS OHSAS 18001) is an internationally applied British Standard for occupational health and safety management systems. It exists to help all kinds of organizations put in place demonstrably sound occupational health and safety performance of any organization including oil & gas industries. The OHSAS 18001 specification gives requirements for an Occupational Health and Safety Management System to control its Occupational Health and Safety (OH&S) risks and improve its performance. Hazard identification, risk assessment and control processes and their outputs is the basis of the whole OH&S management system.

OH&S management system is established to eliminate or minimize risk to employees and other interested parties who may be exposed to OH&S risks associated with its activities. OHSAS 18001 Occupational Health and Safety Standard uses a management approach tool called the PDCA cycle like any other ISO standard. PDCA is an ongoing process that enables an organization to establish, implement and maintain its health and safety policy based on top management leadership and commitment to the safety management system.

The activities carried out in Drilling have various potential to have harm to individual, property or environment known as Hazard.



# What is Hazard?

Hazards are chemical or physical condition that has the potential to cause injury to people, damage to property, or harm to the environment.

Hazards in the oil industry can be categorized as:

- Physical
- Chemical
- Biological
- Psychological
- Ergonomic

Few are in the form of:

- H<sub>2</sub>S Release (Hydrogen Sulfide).
- High Pressure.
- Toxic Chemicals.
- Heavy Equipment/ Tools.
- Sharp edges & Pinching points.
- Flammables & Explosive materials.
- Height – Fall & Drop hazards.



To mitigate these risks involved or to reduce the hazards the company indulges itself in identifying the risk and defining the control measures called Risk assessment. There are quantitative risk Assessment (QRA) or qualitative risk Assessment carried out. The following chart identifies whether the risks are within the acceptable limit or known as “As low as reasonable Practicable (ALARP) in qualitative risk assessment.

		CONSEQUENCE				
		Negligible (1)	Minor (2)	Moderate (3)	Major (4)	Severe (5)
LIKELIHOOD OF OCCURRENCE	Very Unlikely (A)	ACCEPTABLE REGION				
	Unlikely (B)	ACCEPTABLE REGION			ALARP REGION	
	Possible (C)	ACCEPTABLE REGION		ALARP REGION		
	Likely (D)	ACCEPTABLE REGION		ALARP REGION		UNACCEPTABLE
	Frequent (E)	ALARP REGION		UNACCEPTABLE		

Table II.1 Safety Risk Evaluation Matrix



**Safety Risk Evaluation Matrix**

<b>About this Matrix:</b> o This Risk Matrix and risk tolerability criteria are endorsed for use across KOC. o The non-monetary severity columns (People and Reputation) are independent of any monetary relationships and are not intended to be proportionally related to the other Consequence Severity Categories. o Damage to assets includes capital loss, business interruption, production deferment, legal liability and emergency response costs.					
<b>Categories</b>	<b>Decreasing Consequence</b> 				
	<b>Negligible (1)</b>	<b>Minor (2)</b>	<b>Moderate (3)</b>	<b>Major (4)</b>	<b>Severe (5)</b>
<b>People</b>	No injury or damage to people.	Reversible, minor employee injury not affecting work performance, requiring short term hospitalization.	Moderate irreversible impairment to one or more employees that can result in lost workdays (LTI), or restricted work.	Single employee fatality or permanent total disability to one or more employees, and some impact on third parties.	Multiple employee fatalities, and/or multiple third party fatalities.
<b>Assets</b>	Slight damage and/or operational impact with costs up to KD 1.0 million	Minor damage and/or operational impact with costs between KD 1.0 and 15 million	Partial damage and/or operational impact with costs between KD 15 million and KD 30 million	Major damage and/or operational impact with costs between KD 30 million and KD 140 million	Significant damage and/or operational impact with costs above 140 million, e.g. total loss of a facility.
<b>Reputation</b>	Minor, adverse local public and media attention	Attention from media; heightened concern by local community	Criticism by national government	Significant adverse national media or public or national government attention	International public or media attention, with potentially severe impact
<b>Frequency Estimation</b>					
<b>Frequency Category</b>	<b>Qualitative Interpretation Guidance</b>				<b>Quantitative Interpretation Guidance (yr<sup>-1</sup>)</b>
<b>A</b>	Very Unlikely. • Has happened once, or not at all in KOC • Has happened a few times, or not at all in O&G Industry				Less than E-05
<b>B</b>	Unlikely. • Similar event may occur once in 50-100 years at one of KOC assets. • Have been isolated occurrences in KOC or has happened several times in the O&G Industry.				Between E-05 and E-04
<b>C</b>	Possible. • Similar event may occur once in 10 to 50 years at one of KOC assets. • Has not happened before at the Asset or has happened a few times in KOC.				Between E-04 and E-03
<b>D</b>	Likely. • Similar event may occur at Asset every 10 to 50 years. • Has happened once before at the Asset, or several times in KOC.				Between E-03 and E-02
<b>E</b>	Possible. • Similar event may occur at Asset every 1 to 10 years. • Has happened several times at Asset, or many times in KOC				Greater than E-01

In Quantitative risk assessment (QRA) equipment failure probability, Leak frequencies are determined and the effect of each equipment and operation is analyzed in a software to quantify the risk.

After the analysis of the risk ALARP methodology is applied to add control measures or mitigation measures by ERICPD, i.e. eliminate the hazard, reduce the hazard or change it for a safer alternative, isolate the hazard from personnel, control the hazard, Personal protective Equipment (PPE) or add Disciplinary measures.

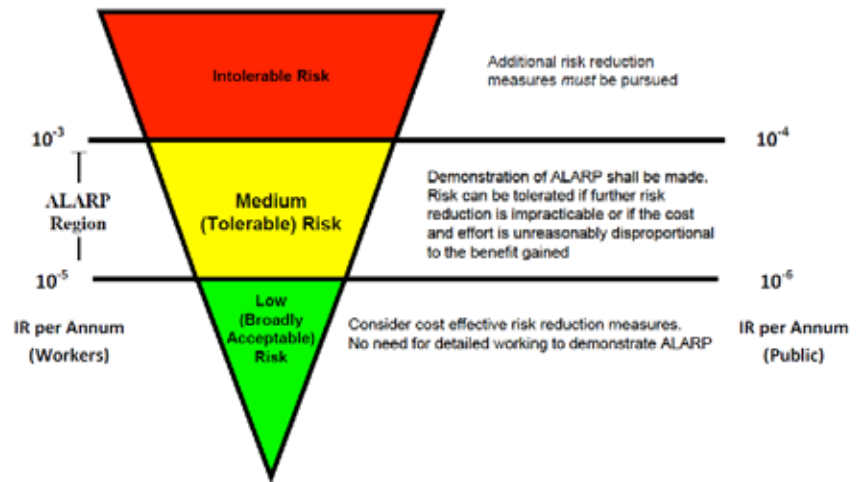

Figure No. 1 - The ALARP Principle and the KOC RTC

Based on the above studies a Risk register is prepared for Safety, Environment Aspects and Health risks along with their control measures. In addition, significant risks identified are add to a yearly plan to rollout and implement these control measures on a set target period.

The planning of an activity depends on the right person at the right job at the right time. It is dependent on the inspected tools and the raw material used for the job. It also depends on the well-maintained equipment or heavy machinery (if required) for the job. The above identified control measures for each activity is added to the Job Safety Analysis (JSA) relating to the same activity.

In the event of a failure or incident, the recommendations of the investigations are considered as control measures and added to the risk register. Thus, in turn assuring the continual improvement of the risk management system.

## HSE Plan & Bridging documents

The business partners have their HSEMS and the clients have theirs. After the contract is awarded both the HSEMS are bridged to form a bridging document. The bridging document clearly states the governing policy in case of a conflict. Business partners build a HSE Plan for the contract and indicates the implementation targets for the contract, which is decided by the bridging document.



## Audit, Inspection, and Self-assessment process

The objectives of the audit, inspection, and self-assessment process are to:

- Evaluate the progress of achieving HSE targets, maintaining regulatory compliance, and effectively utilizing the Health Safety and Environment (HSE) Management System
- Determine that all elements of the HSE Management System have been developed and documented in accordance with applicable regulatory & other requirements and commitments
- Verify that the HSE Management System is adequate to achieve its purpose, has been implemented, and is effective
- Identify and report deficiencies in meeting HSE requirements and commitments
- Verify that corrective actions have been implemented for identified deficiencies

## Personal Protective Equipment (PPE)

After Engineering and Administrative Controls, Personal protective Equipment (PPE) act as the last barrier in protecting the personnel from hazards. Based on hazard identification, required PPE must be selected and used in field areas.

Protective Equipment are categorized as:

- Respiratory Protection
- Non Respiratory Protection
  - Head Protection (Safety Helmet)
  - Face, Ear and Eye Protection
    - Safety Goggles/Glasses
    - Ear Plugs
    - Face shield
  - Hand Protection (Gloves)
  - Body Protection (Coverall, disposable suits)
  - Fall Protection (Self-retrieving lanyards, Full body harness, etc.)
  - Foot Protection (Safety Boots)



\*Note: Additional PPE might be required depending on the job.



## Hydrogen Sulfide Gas

H<sub>2</sub>S is a colorless, highly flammable, toxic and poisonous gas. H<sub>2</sub>S is naturally present in most of the fossil fuels and occurs as a byproduct during production. Understanding and controlling the hazards it presents is literally a matter of life and death.

### CHARACTERISTICS OF HYDROGEN SULFIDE

- Highly Toxic
- Colorless
- Slightly Soluble
- Heavier than Air
- Flammable and explosive
- Corrosive
- Odor is not a reliable warning
- Burning H<sub>2</sub>S emits SO<sub>2</sub>
- Forms pyrophoric material



H<sub>2</sub>S is heavier than air, so it tends to settle in low areas such as Cellar, Shale Shaker, Pumps, inside the tanks, Flow lines, Rig Floor and Ditches.

H<sub>2</sub>S is flammable gas. H<sub>2</sub>S is three times more flammable than natural gas, so the potential of fire or explosion is always a danger.

### Initial Response to H<sub>2</sub>S Alarm

- When alarm (fixed detectors or personal monitor) sounds, stop work, wear appropriate / assigned breathing escape device and evacuate to a safe area immediately.
- Look at the wind sock to know wind direction.
- Move up wind if release is downwind of you.
- Move cross wind if release is upwind of you.
- Move to higher ground if possible.





## During Visit to the Rig

Visitor has to:

- Report to Tool pusher on arrival and departure from well site.
- Get rig safety orientation
- Wear Personal Protective Equipment (PPE) – Safety Helmet, safety footwear, Flame Resistant Coverall, Safety glass, calibrated Personal H2S monitor, etc.
- Observe the rig layout to know the hazardous / restricted areas, to locate the position of fire equipment; H2S escape equipment, and the windsock.
- Locate where the assembly point is.

Always follow the rig information signage such as No smoking sign, High Noise level sign, Dangerous chemical sign, Flammable sign and PPE sign.

- Always follow the rig and company regulations.
- Always be guided by the rig personnel accompanying you.
- In case of an alarm respond immediately. Evacuate quickly and orderly and move to the Muster / Assembly Point.





## 24. Conclusion

In conclusion, oil is important in our life and to our nation's growth. The idea of this book is to serve all oil field employees and entry-level employee to get introduced to the importance of oil and to have an overview of the big picture of the oil industry.

People pumping gas in gas stations tend to take the gasoline for granted by not knowing the efforts taken to produce the gasoline and the petroleum products we use in our daily lives.

The oil industry needs people who are well trained, motivated and interested to enhance the business to overcome the challenges of the hostile environments.

I hope this book meets the need of readers, and adds valuable information to the knowledge of readers.

In closing of this book, I am thankful for all the support and encouragement that I received to achieve the completion of this book.

Maximum effort has been made to ensure the accuracy of the contents and to give credit and copy rights where they are due.



# 25. Appendixes

A. Rig Components	Page	167
B. Conversion Factors		168
C. Tables		172
D. Area Calculations		174
E. Glossary		176

## A. Rig Components

Source: [http://www.osha.gov/SLTC/etools/oilandgas/illustrated\\_glossary.html](http://www.osha.gov/SLTC/etools/oilandgas/illustrated_glossary.html)

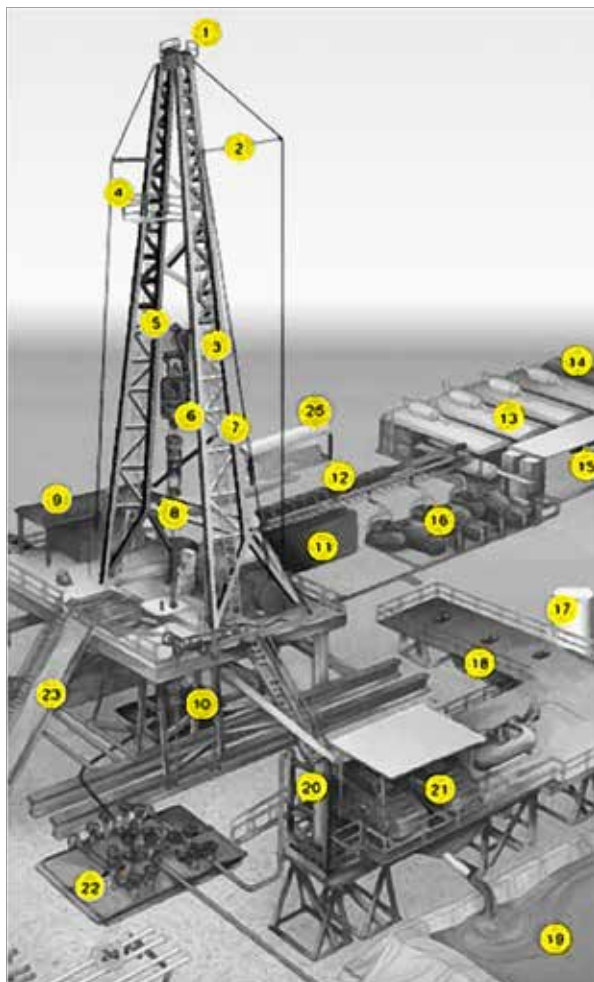

1. CROWN BLOCK AND WATER TABLE
2. CATLINE BOOM AND HOIST LINE
3. DRILLING LINE
4. MONKEY BOARD
5. TRAVELING BLOCK
6. TOP DRIVE
7. MAST
8. DRILL PIPE
9. DOGHOUSE
10. BLOWOUT PREVENTER
11. WATER TANK
12. ELECTRIC CABLE TRAY
13. ENGINE GENERATOR SETS
14. FUEL TANK
15. ELECTRICAL CONTROL HOUSE
16. MUD PUMPS
17. BULK MUD COMPONENT TANKS
18. MUD TANKS (PITS)
19. RESERVE PIT
20. MUD-GAS SEPARATOR
21. SHALE SHAKERS
22. CHOKE MANIFOLD
23. PIPE RAMP
24. PIPE RACKS
25. ACCUMULATOR



## B. Conversion Factors

### Length

Name of Unit	Multiply by	To Obtain
Inches (in.)	25.4	Millimeters (mm)
	2.54	Centimeters (cm)
Feet (ft.)	0.3048	Meters (m)
Yards (yd)	0.9144	Meters (m)
Miles (mi)	1609.344	Meters (m)

### Hole and Pipe diameters, bit size

Name of Unit	Multiply by	To Obtain
Inches (in.)	25.4	Millimeters (mm)

### Drilling Rate

Name of Unit	Multiply by	To Obtain
Feet per hour (ft./hr)	0.3048	Meters per hour (m/h)

### Weight on Bit

Name of Unit	Multiply by	To Obtain
Pounds (lb)	0.445	Decanewtons (dN)

### Nozzle Size

Name of Unit	Multiply by	To Obtain
32 <sup>nd</sup> of an inch	0.8	Millimeters (mm)



## Volume

Name of Unit	Multiply by	To Obtain
Barrels (bbl)	0.159	Cubic meters (m <sup>3</sup> )
	159	Liters (L)
Gallons per stroke (gal/stroke)	0.00379	Cubic meters per stroke (m <sup>3</sup> /stroke)
Ounces (oz.)	29.57	Milliliters (mL)
Cubic Inches (in <sup>3</sup> )	16.387	Cubic Centimeters (cm <sup>3</sup> )
Cubic feet (ft <sup>3</sup> )	28.3269	Liters (L)
	0.0283	Cubic meters (m <sup>3</sup> )
Quarts (qt)	0.9464	Liters (L)
Gallons (gal)	3.7854	Liters (L)
	0.00379	Cubic meters (m <sup>3</sup> )
Pounds per Barrel (lb/bbl)	2.895	Kilogram per Cubic meters (kg/m <sup>3</sup> )
Barrels per ton (bbl/tn)	0.175	Cubic meters per Tonne (m <sup>3</sup> /t)

## Pump Output and Flow rate

Name of Unit	Multiply by	To Obtain
Gallons per minute (gpm)	0.00379	Cubic meters per minute (m <sup>3</sup> /min)
Gallons per hour (gph)	0.00379	Cubic meters per hour (m <sup>3</sup> /h)
Barrel per stroke (bbl/Stroke)	0.159	Cubic meters per stroke (m <sup>3</sup> /stroke)
Barrel per minute (bbl/min)	0.159	Cubic meters per minute (m <sup>3</sup> /min)



## Pressure

Name of Unit	Multiply by	To Obtain
Pounds per square inch (psi)	6.895	Kilopascals (kPa)
	0.006895	Megapascals (MPa)

## Temperature

Name of Unit	Multiply by	To Obtain
Degree Fahrenheit (F)	$(F-32) / 1.8$	Degree Celsius (C)
Degree Celsius	$1.8 (C) + 32$	Degree Fahrenheit (F)

## Thermal Gradient

Name of Unit	Multiply by	To Obtain
1 F per 60 feet	-	1 C per 33 meters

## Mass – Weight

Name of Unit	Multiply by	To Obtain
Ounces (oz.)	28.35	Grams (g)
Pounds (lb)	453.59	Grams (g)
	0.4536	Kilograms (kg)
Tons (tn)	0.9072	Tonnes (t)
Pounds per foot (lb/ft.)	1.488	Kilograms per meters (kg/m)

## Mud Weight

Name of Unit	Multiply by	To Obtain
Pounds per gallons (ppg)	119.82	Kilogram per Cubic meters (kg/m <sup>3</sup> )
Pounds per Cubic feet (lb/ft <sup>3</sup> )	16.0	Kilogram per Cubic meters (kg/m <sup>3</sup> )



## Pressure Gradient

Name of Unit	Multiply by	To Obtain
Pounds per square inches per foot (psi/ft.)	22.621	Kilopascals per meters (kPa/m)

## Funnel Viscosity

Name of Unit	Multiply by	To Obtain
Seconds per quarts (s/qt)	1.057	Seconds per liters (s/L)

## Yield Point

Name of Unit	Multiply by	To Obtain
Pounds per 100 square feet (lb/100 ft <sup>2</sup> )	0.48	Pascals (Pa)

## Gel Strength

Name of Unit	Multiply by	To Obtain
Pounds per 100 square feet (lb/100 ft <sup>2</sup> )	0.48	Pascals (Pa)

## Filter Cake Thickness

Name of Unit	Multiply by	To Obtain
32 <sup>nd</sup> of an inch	0.8	Millimeters (mm)

## Power

Name of Unit	Multiply by	To Obtain
Horsepower (hp)	0.75	kilowatts (kW)



## Area

Name of Unit	Multiply by	To Obtain
Square inches (in <sup>2</sup> )	6.45	Square centimeters (cm <sup>2</sup> )
Square feet (ft <sup>2</sup> )	0.0929	Square meters (m <sup>2</sup> )
Square yards (yd <sup>2</sup> )	0.8361	Square meters (m <sup>2</sup> )
Square miles (mi <sup>2</sup> )	2.59	Square kilometers (km <sup>2</sup> )
Acre (ac)	0.40	Hectare (ha)

## Drilling line wear

Name of Unit	Multiply by	To Obtain
Ton-miles (m.mi)	14.317	mega joules (Mj)
	1.459	Tonne-kilometers (t.km)

## Torque

Name of Unit	Multiply by	To Obtain
Foot – pounds (ft.lb)	1.3558	Newton meters (N.m)

# C. Tables

## Mesh Screen Sizes

Mesh Size	Opening Width (microns)	Mesh Size	Opening Width (microns)	Mesh Size	Opening Width (microns)
8	2,643	20	863	100	140
10	2,108	30	515	120	117
12	1,524	40	381	200	74
14	1,229	50	279	250	50
16	1,143	60	234	325	44
18	965	80	178		



## Hydro cyclones Specifications

Mesh Size	Size (inch)	Volume (gpm)	Micron Cut Point
Desanders	12	450	100
Desanders	8	200	50
Desanders	6	100	30
Desilter	4	60	15-30
Desilter	2	25	10-25

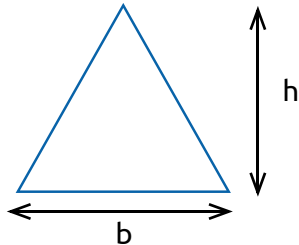
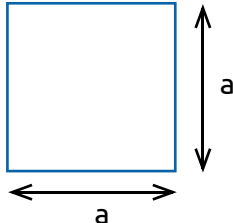
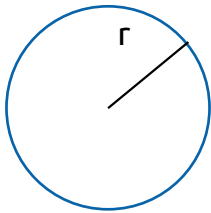
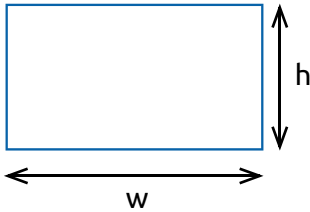

## D. Area Calculations

	<b>Triangle</b> Area = $\frac{1}{2} \times b \times h$ b = base h = vertical height
	<b>Square</b> Area = $a^2$ a = length of side
	<b>Circle</b> Area = $\pi \times r^2$ Circumference = $2 \times \pi \times r$ r = radius
	<b>Rectangle</b> Area = $w \times h$ w = width h = height

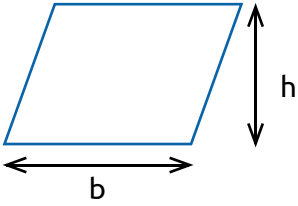
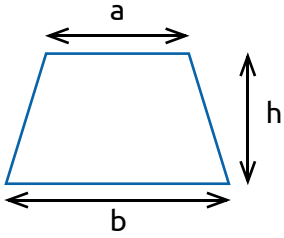
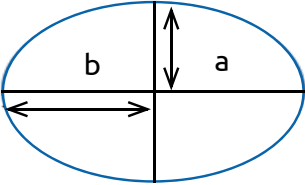
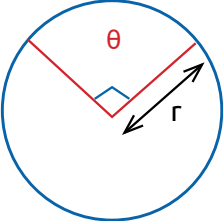

	<p><b>Parallelogram</b></p> <p>Area = <math>b \times h</math></p> <p>b = base</p> <p>h = vertical height</p>
	<p><b>Trapezoid (US)</b> <b>Trapezium (UK)</b></p> <p>Area = <math>\frac{1}{2}(a+b) \times h</math></p> <p>h = vertical height</p>
	<p><b>Ellipse</b></p> <p>Area = <math>\pi \times a \times b</math></p> <p>a = vertical height radius</p> <p>b = base radius</p>
	<p><b>Sector</b></p> <p>Area = <math>\pi \times r^2 \times \theta / 360</math></p> <p>r = radius</p> <p><math>\theta</math> = angle in radians</p>

**Air hoists:** a hoist operated by compressed air; a pneumatic hoist. Air hoists are often mounted on the rig floor and may be used to lift joints of pipe and other heavy objects.



## E. Glossary

### A

**Abandon well:** to cease oil or/and gas production from a well when it reaches economic limit.

**Abnormal pressure:** formation pressure that is greater or less than normal pressure. Normal pressure is 0.465 psi/ft. depth.

**Absolute permeability:** a property of a porous media that allows a 100% saturating fluid to flow through it.

**Absolute porosity:** percentage of bulk volume of a porous media occupied by the pore spaces.

**Accelerator:** a chemical additive used to setting time of cement.

**Acid treatment:** a method by which acid is injected in petroleum bearing formations ie. limestone to enlarge the pore spaces.

**Acoustic survey:** a well logging method used to measure sound travel time through formation.

**Additive:** additives are added to lubricating oil, fuel, drilling mud, and cement.

**Adjustable choke:** a choke in which a conical needle and seat to control flow rates.

**Aeration:** injecting air or gas into a fluid.

**Air drilling:** drilling that uses compressed air as its circulation medium.

**Air hoists:** a hoist operated by compressed air; a pneumatic hoist. Air hoists are often mounted on the rig floor and may be used to lift joints of pipe and other heavy objects.

**Anchor:** any device that secures or fastens equipment.

**Angle of deflection:** the angle at which a well is deflected from the vertical by a deflecting tool.

**Anhydrite:** the common name for calcium sulfate  $\text{CaSO}_4$ .

**Annular blowout preventer:** a valve used to seal the wellbore itself.

**Annular space (annulus):** the space around a pipe in a well bore.

**Anode:** the positive element of any electrical device.

**ANSI:** American National Standards Institute

**Antifreeze:** a compound that prevents the water from freezing.

**Anti-knock compound:** a substance added to the fuel of an internal-combustion engine to prevent detonation of the fuel; specifically, tetraethyl lead.

**API:** the American Petroleum Institute that was established in 1920.

**API gravity:** expressed in degrees by:

$$\text{API gravity} = [141.5 / \text{Specific Gravity}] - 131.5$$



**Artificial lift:** any method used to raise oil to the surface through a well.

**ASME:** American Society of Safety Engineers.

**ASTM:** American Society for Testing and Materials.

**Atmospheric pressure:** the pressure exerted over the surface of the earth by the atmosphere. At sea level, it is about 14.7 psi.

**Atm:** atmosphere.

## B

**Back-pressure:** the pressure maintained on a system to force a fluid to flow.

**Bailer:** a cylindrical container used to remove water, sand, mud, or oil from a well.

**Bailing line:** the cable attached to the bailer.

**Barite:** barium sulfate, BaSO<sub>4</sub>; is used to increase mud weight.

**Barrel:** a measure of volume for petroleum products. One barrel (1 bbl) is equivalent to 42 U.S. gallons / 159 liters.

**Barrel-mile:** a unit of measuring for shipping oil in pipeline, 1 bbl moved 1 mile.

**Barrel per day (BPD, bpd, B/D, b/d):** a unit of measuring flow rate.

**Bentonite:** Colloidal clay, is a major component of drilling muds.

**BHP:** bottom hole pressure.

**BHT:** bottom hole temperature.

**Bit:** cutting element used in drilling oil and gas well used to drill a formation.

**Bit breaker:** a device used to unscrew the bit from the drill string.

**Bit gauge:** a ring used to determine whether the bit has the correct outside diameter.

**Bit record:** a report on each bit, listing its type, the amount of footage it drilled, and the nature of the formation penetrated.

**Blind ram :** the closing element of blowout preventer.

**Bleed:** to drain off liquid or gas through a valve called bleeder.

**Blowout:** an uncontrolled flow of well fluids into the atmosphere.

**Blowout preventer (BOP):** equipment installed at the wellhead to prevent the pressure escape.

**BOP control panel:** a set of controls to open and close the blowout preventers.

**Bomb:** a container used to hold samples of oil or gas under pressure.

**Booster station:** is used to maintain or increase the pressure of a fluid to pump it to the next station or terminal.

**Borehole:** the wellbore.



**Bottled gas:** liquefied petroleum gas placed in small containers.

**Bottomhole assembly (BHA) :** the portion of the drilling assembly below the drill pipe. It can be very simple, composed of only the bit and drill collars, or it can be very complex and made up of several specialty components.

**Bottom-hole choke:** a device placed in the lower end of the tubing to control fluid flow.

**Bottom-hole packer:** a device installed near the bottom of the hole to block passage through the annulus.

**Bottom-hole plug:** a bridge plug or cement plug placed near the bottom of the hole to shut off a zone.

**Bottom-hole pressure:** the pressure at a point opposite to the producing zone.

**Bottom-hole pump:** a pump located near the bottom of the hole.

**Bottom-hole separator:** a device used to separate oil and gas at the bottom of the well.

**Bottom water:** water found below oil and gas in a producing formation.

**Bottoms-up:** a complete trip from the bottom of the wellbore to the top.

**Brackish water:** water that contains low concentrations of soluble salts.

**Break circulation:** to start the mud pump for restoring circulation of the mud column. Because the stagnant drilling fluid has thickened or gelled during the period of no circulation, higher pump pressure is usually required to break circulation.

**Bridge plug :** a downhole tool, composed primarily of slips, a plug mandrel, and a rubber sealing element, that is run and set in casing to isolate a lower zone while an upper section is being tested or cemented.

**Brine :** water that has a quantity of salt, especially sodium chloride, dissolved in it; salt water.

**British thermal unit (BTU):** heat needed to raise the temperature of 1 lb of water 1 degree Fahrenheit.

**Bscf/d:** billion standard cubic feet of gas per day.

**Bubble point:** the temperature and pressure at which first bubble of gas is evolved from liquid.

**Buildup test:** a test in which a well is shut in for a prescribed period of time during which BHP is record.

**Bullet perforator:** a device used to perforate casing.

## C

**Cable tool drilling:** a primitive drilling method in which the hole is drilled by dropping a sharply pointed bit on the bottom of the hole.

**Cake thickness:** the thickness of the filter.

**Calcium-treated mud:** a freshwater drilling mud treated by calcium oxide (lime) or calcium sulfate (Gypsum).

**Cap a well:** to control a blowout by placing a very strong valve on the wellhead.

**Cap rock:** impermeable rock overlying an oil or gas reservoir.

**Carbonate rock:** a rock primarily composed of calcium magnesium carbonate (dolomite).

**Casing:** steel pipe placed in a well as drilling progresses to overcome problems and/or to produce oil and gas.



**Casing centralizer:** a device used to center the casing in the hole.

**Casing coupling:** used to connect two joints of casing.

**Casing head:** a heavy, flanged steel fitting connected to the first string of casing. It provides a housing for slips and packing assemblies, allows suspension of intermediate and production strings of casing, and supplies the means for the annulus to be sealed off. Also called a casing spool.

**Cathead:** a spool-shaped attachment on the end of the catshaft, around which rope for hoisting and moving heavy equipment on or near the rig floor is wound. See breakout cathead, makeup cathead.

**Catwalk:** the elevated work area adjacent to the door and ramp on a drilling rig where pipe is laid to be lifted to the derrick floor by the catline or by an air hoist. See catline. 2. any elevated walkway.

**Cellar:** a pit in the ground to provide additional height between the rig floor and the well head to accommodate the installation of blowout preventers, ratholes, mouseholes, and so forth. It also may collect drainage water and other fluids for subsequent disposal.

**Cement bond:** the adherence of casing to cement and cement to formation. When casing is run in a well, it is set, or bonded, to the formation by means of cement.

**Cement retainer:** a tool set temporarily in the casing or well to prevent the passage of cement, thereby forcing it to follow another designated path. It is used in squeeze cementing and other remedial cementing jobs.

**Company representative or Company Man:** an employee of an operating company who supervises the operations at a drilling site or well site and who may coordinate the hiring of logging, testing, service, and workover companies. Also called company hand, operator's representative, or company man.

**Conductor hole:** the hole where the crew starts the top of the well.

**Conductor pipe:** the largest diameter casing and the topmost length of casing. It is relatively short and encases the topmost string of casing.

**Casing point:** the depth at which the casing shoe sets.

**Casing pressure:** the pressure in the annulus between casing and tubing/drill pipe.

**Cathode:** the negative element of any electric device as opposed to anode.

**Cementing:** the application of placing cement slurry inside or outside the casing.

**Cementing basket:** a collapsible metal cone to prevent the cement passage.

**Cementing head:** a device attached to the casing top to facilitate cementing.

**Cementing time:** the time needed to complete a cementing operation.

**Choke:** an orifice installed in a line to control the production rate.

**Choke manifold:** through which drilling mud is circulated to control the pressure encountered during a kick.

**Christmas tree:** a set of valves, pressure gauges, and choke assembled at the top of a well to control oil and gas flow.



**Circulation:** cycle of drilling fluid out of the mud pits, down the drill stem, up the annulus, and back to the mud pits.

**Clastic rocks:** sedimentary rocks composed of fragments of preexisting rocks.

**Clearance volume:** the space between the traveling and standing valves in a sucker-rod pump when the pump is at the bottom of its stroke.

**Completion fluid:** a special drilling mud used when a well is being completed.

**Concession:** a tract of land a granted by a government to an individual or company for exploration and exploitation minerals.

**Condensate:** a light hydrocarbon liquid obtained by vapors condensation.

**Condensate reservoir:** a reservoir in which both condensate and gas exist in one homogeneous phase.

**Cone-roof tank:** a tank with a fixed conical roof.

**Coning:** the encroachment of reservoir water into the oil column and well.

**Connate water:** the original water retained - in the pore space, or interstices, of a formation from the time the formation was created.

**Core:** a cylindrical sample taken from a formation for geological analysis.

**Critical point:** the point of temperature and pressure at which a fluid cannot be distinguished as being a gas or liquid.

**Critical pressure:** the pressure needed to a condensate a vapor at its critical temperature.

**Critical temperature:** the highest temperature at which a fluid can exist as a liquid or vapor.

**Crooked hole:** a wellbore that has deviated from the vertical.

**Crown block:** an assembly of sheaves, mounted on beams at the top of the derrick.

**Crude oil:** unrefined liquid petroleum.

**Cure:** to age cement under specified conditions of temperature and pressure.

**Cushion:** a column of water or drilling fluid placed inside drill pipe or tubing to prevent it from being crushed by the hydrostatic pressure the fluid in the annulus of the wellbore.

**Cuttings:** the fragments of rock dislodged by the bit and brought to the surface with drilling mud.

## D

**Darcy:** a unit of measure of permeability.

**Deadline:** the drilling line from the crown block sheave to the anchor.

**Deadman:** a buried anchor to which guy wires are tied to steady the derrick, mast, stacks, and so on.



**Dead well:** a well that has ceased to produce oil or gas, either temporarily or permanently.

**Deflection:** a change in the angle of a wellbore. In directional drilling, it is measured in degrees from the vertical.

**Degasser:** the equipment used to remove unwanted gas from a liquid, especially from drilling fluid.

**Degrees API (OAPI):** a unit of measurement of the American Petroleum Institute that indicates the weight, or gravity, of oil.

**Density:** the weight of a substance per unit volume.

**Depthometer:** a device used to measure the depth of a well.

**Depth out:** the depth of the wellbore when a bit is pulled out of the hole.

**Derrick man:** the crew member who handles end of the drill stem as it is being out of or lowered into the hole.

**Desalt:** to remove dissolved salt from crude oil.

**Desander:** a centrifugal device used to remove fine particles of sand from drilling fluid.

**Desilter:** a centrifugal device used to remove very fine particles from drilling fluid.

**Development well:** a well drilled in proven territory in a field to complete a pattern of production.

**Deviation:** the inclination of the wellbore from the vertical.

**Dew point:** the temperature and pressure at which a liquid begins to condense out of a gas.

**Diamond bit:** a drilling bit that has a steel body surfaced with industrial diamonds.

**Differential fill-up collar:** a device used in setting casing.

**Disposal well:** a well into which salt water is pumped.

**Ditch:** a trench or channel made in the earth, usually to bury pipeline, cable, etc.

**Doghouse:** a small enclosure on the rig floor used as an office for the driller.

**Dogleg:** A short change of direction in the wellbore, frequently resulting in the formation of a key seat.

**Drainage radius:** the area of a reservoir in which a single well serves as a point for drainage of reservoir fluids.

**Driller's log:** a record that describes formations encountered and lists drilling time relative to depth, usually in 5- to 10-ft intervals.

**Drilling break:** a sudden increase in the rate of penetration by the drill bit.

**Drilling crew:** a driller, a derrick man, and two or more helpers who operate a drilling or work over rig for one tour each day.



**Drilling foreman:** the supervisor of drilling or workover operations on a rig.

**Dry drilling:** a drilling operation in which no fluid is circulated back up to the surface.

**Dry hole:** any well that does not produce oil or gas in commercial quantities.

## E

**Edgewater:** the water that touches the edge - of the oil in the lower horizon of a formation.

**Edge well:** a well on the outer fringes of a productive subsurface formation.

**Effective permeability:** the permeability of a rock to a fluid in presence of other.

**Effective porosity:** the interconnected pore spaces percentage of the bulk volume of a rock sample.

**Emulsion:** a liquid mixture in which one liquid, termed the dispersed phase, is uniformly distributed in another liquid, called the continuous phase.

**Emulsion breaker:** a system, device, or process used for breaking down an emulsion into two or more easily separated compounds (as water and oil).

**Enhanced recovery:** a method or methods applied to depleted reservoirs to make them productive once again.

**Erosion:** the process by which material (as rock or soil) is worn away or removed (as by wind or water).

**Evaporation loss:** a loss of petroleum fractions to the atmosphere.

**Expansion loop:** a section of a pipeline to allow for expansion and contraction of the line.

**Exploitation:** the development of a reservoir to extract its oil.

**Exploration:** the search for reservoirs of oil and gas, including aerial and geophysical surveys, geological studies, core testing, and the drilling of wildcats.

## F

**Facies:** part of a sedimentary bed of rock that differs significantly from other parts of the bed.

**Fast line:** the end of the drilling line that is affixed to the drum of the draw works.

**Fault:** a break in subsurface strata.

**Fault trap:** a subsurface hydrocarbon trap created by faulting.

**FIH:** fluid in hole.

**Filler material:** a material added to a cement or cement slurry to increase its yield.

**Filter cake:** the compacted solid or semisolid material remaining on a filter after pressure filtration of mud with a standard filter press.



**Filter loss:** the amount of fluid that can be delivered through a permeable filter medium after being subjected to a differential pressure for a specified time.

**Filtrate:** a fluid that has been passed through a filter.

**Fish:** an object left in the wellbore during drilling or workover operations that must be recovered before work can proceed.

**Fishing tool:** a tool designed to recover equipment lost in the well.

**Fissure:** a crack or fracture in a subsurface formation.

**Flare:** a burner used to dispose surplus combustible vapors.

**Flare gas:** gas or vapor that is flared.

**Float collar:** a special coupling device, inserted one or two joints above the bottom of the casing string, that contains a check valve to permit fluid to pass in one direction downward.

**Floating roof:** a tank roof that rests on the surface of a hydrocarbon liquid in the tank. It rises and falls as the liquid level rises and fall.

**Flood:** injecting water and/or gas to drive oil from a reservoir into a well.

**Flowing well:** a well that produces oil or gas by its own reservoir pressure.

**Flow line:** the surface pipe through which oil travels from a well to processing equipment or storage.

**Flow stream samples:** samples of fluid taken at the wellhead or from the flow line.

**Flow tank:** the storage tank to which produced oil is piped.

**Formation pressure:** the force exerted by fluids or gas in a formation, recorded in the hole at the level of the formation with the well shut in. Also called reservoir pressure or shut-in bottomhole pressure.

**Formation testing:** the gathering of pressure data and fluid samples from a formation to determine its production potential before choosing a completion method.

**Formation water:** the water originally in place in a formation.

**Fracture:** a crack in a formation, either natural or induced.

**Fracture acidizing:** a job of injecting acid into a formation under high pressure to crack the formation.

**Free water:** the water produced with oil.

**Free-water knockout (FWKO):** a vertical or horizontal vessel into which water is dropped out of well fluid stream.

**Fresh water:** water that has little or no salt dissolved in it.



## G

**Gas cap:** a free-gas phase overlying an oil zone.

**Gas-cap drive:** drive energy supplied naturally the expansion of gas in a cap overlying the oil in the reservoir.

**Gas-cut mud:** a drilling mud having entrained formation gas that gives the mud a characteristically fluffy texture.

**Gas lift:** the process of lifting fluid from a well by injecting gas down the well.

**Gas-oil contact:** the point of contact between the bottom of gas sand with the top of an oil sand.

**Gas-oil ratio (GOR):** a measure of the volume of gas produced with oil.

**Gas sand:** porous formation from which natural gas is obtained.

**Gas well:** a well that primarily produces gas.

**Gathering line:** a pipeline used in gathering crude oil from wells to a main pipeline.

**Gathering system:** pipeline network and other equipment needed to transport oil and/or gas from wells to the gathering station.

**Gauging hatch:** the opening in a tank or other vessel for measuring and sampling.

**Geophone:** an instrument that detects vibrations passing through the earth's crust.

**Geothermal gradient:** the increase in the temperature of the earth with depth.

**Geothermal reservoir:** a subsurface layer of rock containing steam or hot water.

**Gun barrel:** a settling tank used to separate oil and water in the field.

**Guy line:** a wire line attached to a mast or derrick to stabilize

**Gyroscopic surveying instrument:** a device used to determine direction in and angle to which a wellbore is drifting off the vertical.

## H

**Half-life:** time needed for half of a quantity of radioactive substance to decay.

**Hard water:** water that contains dissolved compounds of calcium and/or magnesium.

**Hayrack:** a rack used to hold pipe on a derrick; a fingerboard.

**Heavy ends:** the parts of a hydrocarbon mixture that have the highest boiling point and highest viscosity.

**Hoist:** an arrangement of pulleys and wire rope or chain used for lifting heavy objects.

**Hole opener:** a device used to enlarge the size of an existing borehole.

**Horsepower (hp):** a measure of the amount of work done by a machine, equal to 33,000 ft-lb per minute.



**Huff-and-puff injection:** (slang) cyclic steam injection.

**Hydrometer:** an instrument used to determine liquid gravity.

**Hydrostatic pressure:** the force exerted by a body of fluid at rest. It increases directly with the density and the depth of the fluid and is expressed in many different units, including pounds per square inch or kilopascals.

## I

**Infilling well:** a well drilled between known producing wells.

**Inhibited acid:** an acid that has been chemically treated before acidizing to lessen its corrosive effect.

**Inhibited mud:** a drilling fluid with added chemicals to prevent clay particles to swell.

**Inhibitor:** an additive used to retard undesirable chemical action in a product.

**Initial set:** the point at which cement slurry begins to harden.

**Injected gas:** a high-pressure gas injected into a formation to maintain or restores reservoir pressure; gas injected in gas-lift.

**Injection well:** is used to inject fluids into an underground stratum.

**In situ combustion:** a method of enhanced oil recovery in which fire is created in the reservoir.

**Interface:** the contact surface between two boundaries of liquids.

**International Association of Drilling Contractors (IADC):** an organization of drilling contractors, oil and gas companies, and service companies that sponsors or conducts research on education, accident prevention, drilling technology, and other matters of interest to its membership and their employees.

**Isopach map:** a geological thicknesses map of subsurface strata.

## J

**Jack-up:** a jack-up drilling rig.

**Jar:** a tool operated mechanically or hydraulically to deliver a heavy hammer blow to objects in the borehole.

**Jet bit:** a drilling bit with nozzles through which drilling fluid is passed in a high velocity stream to improve the bit efficiency.

**Junk:** metal debris lost in a hole.

## K

**KB:** Kelly bushing.

**Kelly:** the heavy steel member, four or six-sided, suspended from the swivel through the rotary table and connected to the topmost joint of drill pipe.

**Kelly bushing:** a device fitted to the rotary table.



**Kelly cock:** a valve installed between the swivel and the Kelly.

**Kick:** an entry of water, gas, oil, or other formation fluid into the wellbore.

**Kickoff:** to bring a well into production.

**Kickoff point (KOP):** the depth in a vertical hole at which a deviated or slant hole is started.

**Kickoff pressure:** the gas pressure required to kick off a well.

**Kill a well:** 1. In drilling, to prevent a threatened blowout. 2. in production, to stop a well from producing oil and gas.

**Knuckle joint:** a deflection tool used in directional drilling.

## L

**Land casing:** to run in casing so it is supported in the casing head by slips.

**Landing depth:** the depth to which the lower end of casing extends.

**Leak-off test:** a gradual pressurizing of the casing after the blown out preventers have been installed to permit estimation of the casing burst point.

**Light crude oil:** a crude oil of relatively high - API gravity (usually 40° or higher).

**Light ends:** the lighter hydrocarbon molecules that comprise gasoline, light kerosene, heptane, natural gas, and so forth.

**Light weight cement:** a cement or cement system that handles stable slurries having densities of less than the optimum weight of neat cement.

**Lignosulfonate:** an organic drilling fluid additive added to drilling mud to minimize fluid loss and to reduce mud viscosity.

**Lime mud:** a drilling mud that is treated with lime.

**Limestone:** a sedimentary rock rich in calcium carbonate.

**Line drive:** a pattern of water flooding.

**Liner:** any string of casing whose top is located below the surface.

**Liner completion:** a well completion in which a screen liner is used.

**Liner hanger:** a slip device that attaches the liner to the casing.

**Liquefied natural gas (LNG):** Natural gas is liquefied.

**Liquefied petroleum gas (LPG):** a mixture of heavier, gaseous, paraffinic hydrocarbons, principally butane and propane.

**Loss of circulation:** complete or partial failure of the mud to return to the surface as it is being circulated in the hole.

**Lost time incident:** an incident in the workplace that results in an injury serious enough that causes the person injured to be unable to work for a day or more.



**Lubricator:** a specially fabricated length of casing or tubing usually placed temporarily above a valve on top of the casing or tubing head.

## M

**Main line:** a large-diameter pipeline between distant points; a trunk line.

**Make a trip:** to hoist the drill stem out of the wellbore and then to return it to the wellbore.

**Manhole:** a hole in the top or side of a tank through which a person can enter.

**Manifold:** an accessory system of piping to divide a flow into several parts, to combine several flows into one, or to reroute a flow.

**Marine riser connector:** a fitting on top of the subsea blowout preventers to which the riser pipe is connected.

**Marker bed:** a distinctive, easily identified rock stratum, especially one used as a guide for drilling.

**Mast:** a portable derrick capable of being erected as a unit.

**Maximum efficiency rate (MER):** the optimum producing rate to achieve maximum oil recovery.

**Maximum water:** the maximum ratio of water to cement that does not cause the water to separate from the slurry on standing.

**Measuring tank:** a calibrated tank that measures volume of liquid run in.

**Mercaptan:** has an offensive odor and are used as odorants in natural gas.

**Mixing tank:** any tank or vessel used to mix substances such as mixing additives with drilling mud.

**Mole:** the quantity of a substance whose unit - weight is numerically equal to the molecular weight of the substance.

**Molecule:** the smallest part of a substance that can exist on its own.

**Monkeyboard:** the derrick man's working platform.

**Mousehole:** an opening in used to store a drill pipe.

**Mud:** the liquid made from water with some additives to be used in drilling.

**Mud additive:** any material added to drilling fluid to change some of its properties.

**Mud cake:** the sheath of mud solids that forms on the wall of the hole; also called well cake or filter cake.

**Mud conditioning:** treatment of drilling mud to ensure that it has the proper gel strength, viscosity, density, etc.

**Mud hose:** a reinforced, flexible rubber tube through which drilling mud flows from the standpipe to the gooseneck; also called the rotary hose.

**Mud log:** a record of information derived from examination of drilling fluid and cuttings.

**Mud weight:** density of a drilling fluid in pounds per gallon (ppg), pounds per cubic foot (lb/ft<sup>3</sup>), or kilograms per cubic meter (kg/m<sup>3</sup>).



## N

**Natural gas:** a mixture of hydrocarbons occurring naturally in a gaseous form.

**Neat cement:** a cement with no additives other than water.

## O

**Odorant:** a chemical, usually a mercaptan that is added to natural gas so that the presence of the gas can be detected by the smell.

**Off-production:** shut in or temporarily unable to produce (of a well).

**Offshore drilling:** drilling for oil in an ocean or large lake.

**Oil and gas separator:** production equipment used to separate liquid components of the well stream from the gaseous elements.

**Oil-base mud:** an oil mud that contains up to 5 percent water.

**Oil-emulsion mud:** water-base mud in which water is the continuous phase and oil is dispersed phase.

**Oil in place:** the amount of crude oil present in a reservoir.

**Oil mud:** a drilling mud in which oil is the continuous phase.

**Oil sand:** any formation that yields oil.

**Oil shale:** a shale formation containing hydrocarbons.

**Oil slick:** a film of oil floating on water, considered a pollutant.

**Oil spill:** a quantity of oil that has leaked onto the ground or surface of water such as sea, lakes, etc.

**Oil-water contact:** the point of contact between the bottom of an oil sand with the top of a water sand

**OPEC:** the Organization of Petroleum Exporting Countries.

**Open hole:** any wellbore in which casing has not been set.

**Open-hole completion:** a method of completion without production casing or liner.

**Optimum water:** the amount of water used to give a cement slurry the best properties.

**Outcrop:** the exposed portion of a buried layer of rock.

**Out-of-gauge bit:** a bit that is no longer of the proper diameter.

**Overburden pressure:** the pressure exerted by the overburden on the formation targeted for drilling.

## P

**Packer:** a downhole equipment, consisting of a sealing device, a holding or setting device, and an inside passage for fluids.



**Packer fluid:** a liquid, usually mud but sometimes salt water or oil, used in a well when a packer is between the tubing and casing.

**Pay sand:** the producing formation. It is also called pay, pay zone, and producing zone.

**Pay string:** the production casing.

**Perforated completion:** a well completion in which the production casing or liner is perforated.

**Perforate underbalanced:** to perforate the well with a column of fluid in the wellbore.

**Perforating gun:** a device used to create penetration holes in casing, cement, and formation.

**Perforation:** a hole made in the casing cement and formation through which formation fluids enter a wellbore.

**Pig:** a scraping tool to clean out accumulations of wax, scale, and so forth, from the inside walls of a pipe.

**Polymer mud:** a drilling mud to which a polymer has been added.

**Porosity:** fraction of rock occupied by pores.

**Portable mast:** a mast mounted on a truck and, capable of being erected as a single unit.

**Pressure drop:** a loss of pressure due to friction as a fluid passes from one point to another.

**Pressure gradient:** a uniform variation of pressure from point to point.

**Primary cementing:** the cementing operation that takes place immediately after the casing has been run into the hole.

**Primary recovery:** oil production due to natural energy.

**Producing zone:** the zone or formation from which oil or gas is produced.

**Production:** the operation of bringing well fluids to the surface and separating facilities.

**Production casing:** the last string of casing or liner that is set in a well.

**Production log:** a well-logging method that measures and records the fluid flow; a spinner survey.

**Production packer:** any packer designed to make a seal between the tubing and casing during production.

**Production tank:** a tank used in the field to receive crude oil as it comes from the well.

**Prover tank:** a small, mobile tank used to check the accuracy of meters; a calibration tank.

**Pump ability:** the physical characteristic of a cement slurry that determines its ability to be pumped.

## R

**Rabbit:** a small plug that is run through a flow line to clean the line or to test for obstruction.

**Radial flow:** the flow of fluids into a wellbore from the surrounding drainage area.

**Radioactive tracer:** a radioactive material put into a well to allow observation of fluid or gas movements by means of a tracer survey.



**Ram:** the closing and sealing component on a blowout preventer.

**Rate of penetration (ROP):** a measure of the speed at which the bit drills into formations, feet per hour.

**Rathole:** a hole in the rig floor 30 to 35 feet deep, into which the Kelly and swivel are placed when hoisting operations are in progress.

**Ream:** to enlarge the wellbore by drilling it again with a special bit.

**Recovery:** the total volume of hydrocarbons that has been or is anticipated to be produced from a well or field.

**Recovery factor:** The percentages of oil or gas in place in a reservoir that ultimately can be withdrawn by primary and/or secondary techniques.

**Relative permeability:** the effective permeability divided by the absolute permeability.

**Reserves:** the unproduced but recoverable oil or gas in place in a formation that has been proved by production.

**Reservoir:** a subsurface, porous, permeable rock body in which oil or gas or both are stored.

**Retarder:** a chemical compound (as gypsum, lime, , etc.) that is used to prolong the thickening, setting, or hardening time of oil-well cements.

**Returns:** the mud, cuttings, and so forth that circulate up the hole to the surface.

**Reverse circulation:** the return of drilling fluid through the drill stem.

**Roughneck:** a worker on a drilling or workover rig, subordinate to the driller; sometimes called a rotary helper, floorman, or rig crewman.

**Roundtrip:** pulling out drill pipe or tubing and running in the hole.

**Roustabout:** a worker who assists the foreman in the general work.

## S

**Salt-brine cement:** a cementing slurry whose liquid phase contains sodium chloride.

**Salt dome:** a dome that is formed by the intrusion of rock salt into overlying sediments.

**Salt water:** a water that contains a large quantity of salt; brine.

**Saltwater disposal:** system for the salt water disposal.

**Saltwater mud:** a drilling mud in which the water has appreciable amounts of salt dissolved in it.

**Sampler:** a device attached to a flow line to permit continuous sampling of the oil or gas.

**Samples:** cuttings obtained during drilling.

**Scraper:** a device used to remove deposits from tubing, casing, rods, or flow lines.

**Scratcher:** a device fastened to the outside of casing that removes the mud cake from the wall of the hole to condition the hole for cementing.



**Screen liner:** a liner that is perforated and arranged with a wire wrapping to act as a sieve to prevent or minimize the entry of sand particles into the wellbore.

**Scrubber:** a vessel through which fluids are passed to remove dirt and other foreign matter.

**Secondary cementing:** cementing operation after the primary one.

**Secondary recovery:** additional recovery due to water or gas injection.

**Shale shaker:** a series of trays with sieves that vibrate to remove cuttings from the circulating fluid.

**Sidetrack:** to drill around broken drill pipe or casing that has become lodged permanently in the hole.

**Sidewall coring:** a coring technique especially useful in soft rock areas in which core samples are obtained from a zone that has already been drilled.

**SIDPP:** shut-in drill-pipe pressure.

**SIP:** shut-in pressure.

**Skin:** damaged zone adjacent to the wellbore due to mud filtration.

**Slip -and-cutoff program:** a procedure to ensure that the drilling line wears evenly throughout its life. After a specified number of ton-miles (megajoules) of use, the line is slipped—for example, the traveling block is suspended in the derrick or propped on the rig floor so that it cannot move, the deadline anchor bolts are loosened, and the drilling line is spooled onto the drawworks drum. Enough line is slipped to change the major points of wear on the line, such as where it passes through the sheaves. To prevent excess line from accumulating on the drawworks drum, the worn line is cut off and discarded.

**Slurry:** a mixture of cement and water.

**Slurry viscosity:** the consistency of a slurry, measured in poise.

**Slurry volume:** volumes of solids and liquids that constitute a slurry.

**Slurry yield:** the volume of slurry obtained when one sack of cement is mixed with the desired amount of water and additives.

**Spear:** a fishing tool used to retrieve pipe lost in a well.

**Spud:** to begin drilling a well; such as, to spud in. 2. to force a wireline tool or tubing down the hole by using a reciprocating motion.

**Squeeze cementing:** the forcing of cement slurry by pressure to specified points in a well.

**Stabilizer:** a tool placed above the used to change the deviation angle in a well.

**Standard derrick:** a derrick that is built piece by piece at the drilling location.

**Standard pressure:** the pressure exerted by a column of mercury 760mm high; equivalent to 14.7 psia.



**Standard temperature:** a predetermined temperature used as a basic measurement.

**Standpipe:** a vertical pipe rising along the side of the derrick or mast, which joins the mud pump to the rotary hose.

**Stands:** the connected joints of pipe racked in the derrick or mast when making a trip.

**Static fluid level:** the level to which fluid rises in a well when the well is shut in.

**Stock-tank oil:** oil as it exists at atmospheric conditions in a stock tank.

**Stopcock:** a valve that shuts off or regulates fluid flow.

**Storage gas:** gas that is stored in an underground reservoir.

**Storage tank:** a tank in which oil is stored.

**Straddle packer:** two packers separated by a spacer of variable length.

**Storm Choke:** a proprietary name for a tubing safety valve.

**Straight hole:** a hole that is drilled vertically so that no part of the hole is more than 3 degrees off the vertical per 100 ft. of hole.

**String:** the entire length of casing, tubing, drill pipe run into a hole; the casing string.

**Sweet light crude oil:** is a type of petroleum. Petroleum with less than 0.42% sulfur considered as "sweet". Petroleum containing higher levels of sulfur is called sour crude oil.

**Submersible pump:** a pump placed below the level of fluid in a well.

## T

**Tanker:** a ship designed to transport oil, LPG, LNG, or SNG; also called a tank ship.

**Tank farm:** a group of large tanks maintained by a pipeline used to store oil before transportation to the refinery.

**Tar sands:** a sandstone that contains mostly tarlike hydrocarbons.

**Temperature gradient:** the rate of change of temperature with displacement in a given direction.

**Terminal:** a point to which oil is transported through pipelines.

**Tertiary recovery:** a recovery method used to recover additional hydrocarbons after secondary methods.

**Test separator:** an oil and gas separator used to separate relatively small quantities of oil and gas.

**Thickening time:** the length of time a slurry which can be pumped, up to 100 poises.

**Thinning agent:** a special chemical added to a drilling mud to reduce its viscosity.

**Tool pusher:** a drilling foreman or superintendent.

**Total depth (TD):** the maximum reached in a well.



**Tracer:** a substance injected in reservoir to be traced.

**Trap:** formation where petroleum accumulates.

**Trunk line:** a mainline line.

## U

**Ultimate recovery:** total anticipated recovery of oil or gas from a well, leases, or pool.

## V

**Vaporization:** converting a substance into the vapor Phase.

**Vapor pressure:** the pressure exerted by the vapor of a substance when the substance and its vapor are in equilibrium.

**Viscometer:** a device used to determine the viscosity of a substance; also called a viscosimeter.

## W

**Waiting on cement (WOC):** duration of suspending drilling or completion so the cement in a well can harden sufficiently.

**Washout:** excessive wellbore enlargement.

**Washover:** the operation during which stuck drill stem or tubing is freed.

**Water-base mud:** a drilling mud in which the continuous phase is water.

**Water-cement ratio:** the ratio of water to cement in a slurry.

**Water-drive:** the reservoir-drive mechanism in which oil is produced by the expansion of the underlying water.

**Watered out:** of a well, having gone to water.

**Water encroachment:** the movement of water into a producing formation.

**Water flood:** a method of secondary recovery in which water is injected into a reservoir to recover more oil.

**Water string:** a string of casing used to shut off water above an oil sand.

**Water table:** the underground level at which water is found.

**Weight indicator:** an instrument on a drilling or workover rig that shows WOB.

**Weighting material:** a material used to increase the density of drilling fluids or cement slurries.

**Weight up:** to increase the specific gravity, or density, of the drilling fluid by adding weighting material.

**Well:** the hole made by the drilling bit.



**Wellhead:** the equipment used to maintain - surface control of a well.

**Well spacing:** the regulation of the number and location of wells over a reservoir as a conservation measure.

**Well stimulation:** any operation used to increase the production of a well.

**Wet gas:** a natural gas containing an appreciable amount of heavier hydrocarbons, which are often liquid.

**Wet oil:** an oil that contains water.

**Wettability:** the relative affinity between individual grains of rock and each fluid that is present in the spaces between the grains.

**Whip stock:** a long, steel casing that uses an inclined plane to cause the bit to deflect from the original borehole at a slight angle.

**Wildcat:** a well drilled in an area where no oil or gas production exists.

**Wild well:** a well that has blown out of control and from which oil, water, or gas is escaping with great force to the surface; also called a gusher.

**Work over:** to perform one or more of a variety of remedial operations on a producing oil well to try to increase production.

**Workover fluid:** a special drilling mud used to keep a well under control when it is being worked over.



## E. Index

### A

**Abandon**, 150  
**Abnormal pressure**, 138  
**AC Power**, 38  
**Accumulators**, 51, 61  
**Additive**, 102, 112  
**Alkalinity**, 92, 94, 138  
**Air compressor**, 52, 82  
**Alarm**, 82, 179  
**Alcohol**, 164  
**Annular blowout preventer**, 50, 60  
**Annular space (annulus)**, 42 69,102  
**Annular velocity**, 132  
**Annular volume**, 130  
**Anticlines**, 17  
**API**, 191  
**API gravity**, 149, 191  
**Apparent viscosity**, 134  
**Area calculations**, 189, 190  
**Aromatics**, 162  
**Artificial lift**, 145  
**Asphalt**, 158  
**Assembly point**, 180  
**Assistant driller**, 105  
**Auxiliary**, 59  
**Auxiliary Brakes**, 40, 70

### B

**Balance mud weight**, 128  
**Balance plug**, 129  
**Banana truck**, 99  
**Barite**, 41, 95,115, 1367  
**Batch mixer**, 103



**Bell nipple, 69**  
**Bentonite, 95 136, 192**  
**Bit, 72, 91, 96, 101, 112**  
**Bit balling, 113**  
**Blind ram, 192**  
**Blowout preventer (BOP), 48, 50**  
**Booster station, 192**  
**Booster pumps, 167**  
**Borehole, 41, 112**  
**Bottom-hole plug, 193**  
**Brake, 40, 70**  
**Breathing air compressor, 82**  
**Bridge plug, 143, 193**  
**Buoyancy factor, 117**  
**Buoyancy force, 128**  
**Buoyancy weight, 117**  
**Butadiene, 159, 162**

## C

**Caliper Logs, 34**  
**Carbon dioxide, 113, 147**  
**Cascade system, 81**  
**Cased hole completion, 140**  
**Casing, 79, 98, 101**  
**Casing centralizer, 99, 194**  
**Casing head, 68, 148, 194**  
**Cat head, 71**  
**Cat line, 55**  
**Cat walk, 67, 194**  
**Cellar, 31, 68, 194**  
**Cementing, 102-103**  
**Cementing head, 103, 194**  
**Cementing slurry, 54, 98, 102, 197, 202**  
**Cementing unit, 103**  
**Centrifugal force, 66, 96**  
**Centrifuges, 96, 97**  
**Chemical functions, 33, 41, 95, 104, 106, 113, 144, 146, 159, 200, 205, 207**



**Choke**, 48, 50, 51, 63, 115  
**Choke control**, 115, 148  
**Choke manifold**, 48, 50, 51, 63, 194  
**Christmas tree**, 148, 194  
**Circulation**, 30, 41, 43, 46, 94, 110, 195  
**Combination traps**, 16  
**Companies**, 104  
**Completion**, 140 - 148  
**Completion types**, 142  
**Cone capacities**, 138  
**Conductor pipe**, 68, 99, 194  
**Conversion factors**, 183- 187  
**Core**, 34, 195  
**Corrosion**, 102, 113  
**Critical RPM**, 135  
**Crown block**, 39, 57, 195  
**Crude oil export**, 25, 26, 149, 165- 168  
**Crude oil products**, 151 - 164  
**Crude oil separations**, 151, 152  
**Crude oil transport**, 26, 165-168, 207  
**Crown-o-matic**, 71

## D

**DC Power**, 38  
**Dead line anchor**, 71  
**Degasser**, 65, 66, 96  
**Delineation Well**, 34  
**Density**, 34, 91, 95, 132, 145, 149, 195, 200  
**Density Logs**, 34, 104, 140, 202  
**Derrick**, 39, 56, 206  
**Derrick man**, 56, 106, 115, 196  
**Desander**, 41, 66, 96, 138, 188, 196  
**Desilter**, 41, 66, 96, 138, 188, 196  
**Development well**, 35, 84, 196  
**Deviated well**, 86  
**Diamond bit**, 46, 196  
**Differential sticking**, 92, 111  
**Diesel electrical engine**, 38, 59, 60, 84



**Diesel fuel**, 150 151, 155, 166  
**Directional wells**, 86 - 89  
**Disposal well**, 36  
**Distillation**, 151, 153  
**Diverter**, 61  
**Doghouse**, 58  
**Double studded adapter**, 61  
**Drag**, 113  
**Draw works**, 40, 69  
**Drill collar**, 72  
**Drill collar calculations**, 119  
**Drill collar level drop**, 120  
**Drill pipe**, 58  
**Drill pipe failure**, 110  
**Drill pipe level drop**, 118  
**Drill pipe pressure drop**, 119  
**Drill ship**, 83  
**Driller**, 105  
**Driller's console**, 72  
**Driller's log**, 34  
**Drilling activities**, 104  
**Drilling bit**, 45, 196  
**Drilling calculations**, 116 - 139  
**Drilling company**, 104  
**Drilling crew**, 105 - 109  
**Drilling fluids**, 34, 90 - 95  
**Drilling fluids engineer**, 106  
**Drilling instruments**, 53  
**Drilling line**, 70  
**Drilling liner**, 98  
**Drilling problems**, 110 - 115  
**Drilling spool**, 62  
**Drilling rig**, 83- 89  
**Dry drilling**, 197  
**Dry hole**, 33, 197  
**Duplex pump**, 116



## E

**Electrician**, 106  
**Electricity Generator**, 38, 59, 60  
**Electric cable tray**, 59  
**Electric motor**, 59  
**Electric house**, 60  
**Electromagnetic brake**, 40, 70  
**Elevators**, 73  
**Elmago brake**, 40  
**Engine generator set**, 38, 59, 60  
**Equivalent circulating density (ECD)**, 132 - 134  
**Escape line**, 73  
**Ethanol**, 164  
**Ethylene**, 159  
**Ethylene glycol**, 161  
**Evacuation**, 179  
**Exploration**, 14-24, 197

## F

**Fann reading**, 134  
**Fann viscometer**, 92  
**Fast line**, 197  
**Fault**, 16  
**Fault trap**, 17  
**Filter cake**, 94  
**Filter loss**, 198  
**Filtrate**, 94  
**Filtration**, 91, 94  
**Final circulating pressure**, 126  
**Firing gun**, 143  
**Fishing**, 115  
**Fishing tool**, 115  
**Fixed gas detector system**, 82  
**Float collar**, 99  
**Floor hands**, 106  
**Force**, 125  
**Forklift operator**, 107  
**Formation pressure**, 126



**Fracture, 127**  
**Fracture acidizing, 144**  
**Fracture gradient, 123**  
**Fracture mud weight, 123**  
**Fracture pressure, 123**  
**Fresh water gradient, 139**  
**Fresh water mud, 90**  
**Fuel Tank, 59**

## G

**Gas lift, 145**  
**Gasoline, 151**  
**Gathering center, 166**  
**Gathering station, 166**  
**Gel strength, 94**  
**Geology, 14 - 17**  
**Geophysical Survey, 19 - 24**  
**Geronimo, 73**  
**Grease, 157**  
**Gravel pack, 141**  
**Gravimetric Survey, 19**  
**Guide shoe, 99**

## H

**Hazards, 175**  
**Heating oil, 151**  
**Heavy crude oil, 149**  
**Hoisting line, 70**  
**Hoisting system, 39**  
**Hole deviation, 112**  
**Hook, 57**  
**Horizontal well, 89, 112, 141**  
**Horsepower (hp), 40**  
**HSE, 169 - 180**  
**Hydraulics, 132**  
**Hydrocarbons, 11- 13**  
**Hydrogen sulfide, 113, 179**  
**Hydrostatic pressure, 49, 122, 123**



## I

**Igneous rock**, 14  
**Inhibited mud**, 90  
**Initial circulating pressure**, 126  
**Injection well**, 200  
**Inside BOP**, 62  
**Intermediate casing**, 100

## J

**Jack-up**, 83  
**Jet fuel**, 152

## K

**Kelly**, 74  
**Kelly bushing**, 74  
**Kelly cock**, 74  
**Key seat**, 114  
**Kelly spinner**, 75  
**Kerosene**, 152, 115  
**Kick**, 48, 50, 109  
**Kill mud weight**, 126

## L

**Laminar flow**, 92  
**Land rig**, 83  
**Leak-off test**, 139  
**Light crude oil**, 149  
**Liner**, 100, 141  
**Liquefied petroleum gas (LPG)**, 154  
**Location Preparations**, 30 - 32  
**Logistics**, 31  
**Loss of circulation**, 110  
**Loss zone**, 110  
**Lubricating oil**, 157  
**Lubricator**, 75

## M

**MAASP**, 127  
**Main Brake**, 40



**Magnetic Field Survey, 19**  
**Manifold, 48, 51, 63**  
**Marsh funnel, 93, 138**  
**Mast, 39, 56**  
**Mechanic, 106**  
**Mechanical sticking, 112**  
**Metamorphic rock, 14**  
**Micron cut point, 138**  
**Micron size, 137**  
**Mixing hopper, 41**  
**Molecule, 11**  
**Monkeyboard, 56**  
**Mousehole, 75**  
**Mud, 41**  
**Mud additive, 95**  
**Mud balance, 92**  
**Mud building, 135 - 139**  
**Mud cake, 111**  
**Mud cleaner, 97**  
**Mud conditioning, 99**  
**Mud control, 115**  
**Mud cross, 62**  
**Mud cycle, 42, 43**  
**Mud engineer, 106**  
**Mud gas separator, 65**  
**Mud log, 34**  
**Mud properties, 91**  
**Mud pit, 64**  
**Mud pump, 41, 63**  
**Mud return line, 76**  
**Mud storage, 52**  
**Mud system, 90**  
**Mud tanks, 41**  
**Mud weight, 91**  
**Multi gas detector, 82**  
**Multi zone completion, 140**  
**Multiple logs, 34**



## N

- Natural gas**, 12
- Naphtha**, 151, 154, 159
- Newtonian fluids**, 92
- Night tool pusher**, 105
- Non- Newtonian fluids**, 92

## O

- Offshore drilling**, 83
- Oil-base mud**, 91
- Oil Cycle**, 26
- Olefin**, 159
- Open hole completion**, 141
- Operating company**, 104
- Overburden gradient**, 139
- Over pull**, 122

## P

- Packer**, 100, 143, 144
- Pay zone**, 140, 144
- PDC bits**, 46
- Perforated completion**, 142
- Perforating gun**, 143
- Perforation**, 142
- Personal protective equipment**, 178
- Permeability**, 16
- Petrochemical products**, 157- 164
- Petroleum**, 149, 151
- Petroleum coke**, 156
- PH**, 92, 94, 95, 138
- Pipe lines**, 149, 166
- Pipe rack**, 67
- Pipe ramp**, 67
- Pipe volume**, 116
- Plankton**, 12, 13
- Plastic viscosity**, 92, 94, 134
- Poly vinyl chloride PVC**, 160
- Polyethylene**, 160



**Porosity**, 15, 16  
**Porosity Logs**, 34  
**Power Slips**, 77  
**Power System**, 37  
**PPE**, 178  
**Pre- Drilling Operations**, 30 - 32  
**Pressure**, 117  
**Pressure Drop**, 119  
**Pressure gradient**, 124  
**Primary cementing**, 102  
**Primary well control**, 49  
**Producer Well**, 35  
**Producing zone**, 140  
**Production**, 140, 148  
**Production casing**, 98, 100  
**Production liner**, 95, 97  
**Production tubing**, 100  
**Propylene**, 161  
**Pulsation Dampeners**, 63  
**Pump output**, 116, 139  
**Pump rate**, 116  
**PVC**, 160

## R

**Ram preventer**, 50, 60  
**Rate of penetration (ROP)**, 45  
**Rathole**, 76  
**Refineries**, 151 - 156  
**Reservoir**, 15  
**Reserve/ Waste pit**, 31, 65  
**Returns**, 41 - 43  
**Rheology**, 92  
**Rig components**, 55  
**Rig control**, 155  
**Rig crew**, 105, 108  
**Rig move**, 31  
**Rig personnel**, 105 - 109  
**Rig up**, 31  
**Rig Inspection**, 178



**Rig superintendent, 105**

**Rig visit, 180**

**Rock cycle, 14**

**Roller cone bits, 45**

**Rotary drilling, 37**

**Rotary hose, 76**

**Rotary system, 44**

**Rotary table, 74**

**Roughneck, 106**

**Roustabout, 108**

## S

**Sack of cement, 129**

**Safety, 168**

**Safety officer, 107**

**Safety valve, 62**

**Salt dome, 16, 86**

**Sample log, 34**

**Sand screen, 141**

**Seismic Survey, 18 - 24**

**Semisubmersibles, 83**

**SCBA, 81**

**SCR, 38, 60**

**Seating nipple, 143**

**Secondary cementing, 102**

**Secondary well control, 50**

**Sedimentary, 14**

**Service Company, 104**

**Shale shaker, 34, 65, 96, 97**

**Shear rate, 92**

**Shear stress, 92**

**Slips, 77**

**Slotted liner, 141**

**Slug displacement, 118**

**Slug volume, 118**

**Slug weight, 118**

**Slurry, 102**

**Solid control, 96**



**Spacer, 130**  
**Specific gravity, 125**  
**Spinning Chain, 78**  
**Stairways, 78**  
**Standpipe, 79**  
**Stands, 44**  
**Steam flood process, 146**  
**Steel displacement, 117**  
**Stratigraphic Traps, 17**  
**Stretch, 121**  
**Strokes, 116**  
**Structural Traps, 16**  
**Stuck pipe, 120**  
**Substructure, 79**  
**Subsurface safety valve, 144**  
**Super rig, 84**  
**Surface casing, 79, 98, 99**  
**Surface control, 148**  
**Sweet light crude oil, 149**  
**Swivel, 80**  
**Synclines, 17**  
**Synthetic muds, 91**

## T

**Tanker, 165**  
**Tank farm, 167, 168**  
**Tongs, 80**  
**Tool pusher, 105**  
**Top drive, 47, 58**  
**Top plug, 102**  
**Torque, 117**  
**Trap, 16, 17**  
**Travelling Block, 40, 57**  
**Triplex pump, 42, 116, 139**  
**Trip tank, 52**  
**Tripping, 53, 117**  
**Tubing, 100, 140, 144**  
**Tubing head, 148**  
**Turbulent flow, 92**



## U

**Unsolidated rock, 141**

## V

**Velocity Logs, 34**

**Vibratory screening, 96**

**Viscometer, 93**

**Viscosity, 92**

**Volumes, 116**

## W

**Walkways, 80**

**Water-base emulsion, 91**

**Water Source, 30**

**Water Tank, 64**

**Wax, 158**

**Weight indicator, 81**

**Well casing, 79, 98-101**

**Well cementing, 102- 103**

**Well control, 48 115, 122**

**Wellhead, 143**

**Well logging, 34**

**Well Planning, 27 - 29**

**Well stimulation, 144- 147**

**Well Testing, 34**

**Wildcat, 33**

**Wild well, 33**

**Work over, 35, 84**

## Y

**Yield Point, 92, 94, 134**



## 26. References:

1. Oil 101, Morgan Downey, First Edition, Wooden Table Press LLC 2009.
2. A primer of Oil Well Drilling, Dr. Paul Bommer, Seventh Edition, The University of Texas 2008.
3. Al – Neft, Mohammed El-Sayed Mohammed Osman, PHD, English Edition 2011, Kuwait Oil Company.
4. Fundamentals of Oil & Gas Accounting By Charlotte J. Wright, Rebecca A. Gallun.
5. Fundamentals of Petroleum, Kate Van Dyke, Fourth Edition, Petroleum Extension Service, 1997.
6. Drilling Technology in nontechnical Language, Steve Devereux, PennWell Corporation, 1999.
7. The Petroleum Industry A Nontechnical Guide, Charles F. Conaway, PennWell Corporation, 1999.
8. The Rotary Rig and Its Components, K. R. Bork, Fourth Edition, Petroleum Extension Service, 1995.
9. Drilling Fluids, K. R. Bork, First Edition, Petroleum Extension Service, 2000.
10. Practical Petroleum Geology, Jeff Morris, Richard House, Annes McCann-Baker, Petroleum Extension Service, 1985.
11. Basic Well Log Analysis, George Asquith and Daniel Krygowski, Second Edition, The American Association of Petroleum Geologists, 2004.
12. Trouble-Free Drilling, John Mitchell, Drilbert Engineering Inc., 2001.
13. Formulas and Calculations for Drilling, Production, and Workover. Norton J. Lapeyrouse, Second Edition, Gulf Professional Publishing, 2002.



## Websites:

- <http://en.wikipedia.org>
- <http://www.osha.gov>
- <http://www.rigzone.com>
- <http://www.universetoday.com>
- <http://www.priweb.org>
- <http://www.daukas.com>
- <http://www.earthscrust.com>
- <http://www.aurorageoscience.com>
- <http://www.cougarlandservices.net>
- <http://www.kx-kp.com>
- <http://www.dickalive.blogspot.com>
- <http://www.drillingstructuresintl.com>
- <http://www.spescusc.org>
- <http://www.diytrade.com>
- <http://www.wintermud.com>
- <http://www.drillingclub.proboards.com>
- <http://www.drillingahead.com>
- <http://www.intragaz.com>
- <http://www.petrowiki.org>
- <http://www.eurosul.com>
- <http://www.universaloilfield.org>
- <http://www.oilfieldsequipments.com>
- <http://www.slb.com>
- <http://www.oilrigdrillings.com>
- <http://www.petrostrategies.org>
- <http://www.mpgpetroleum.com>
- <http://www.arabianoilandgas.com>
- <http://www.tiptonceram.com>
- <http://www.youtube.com>
- <http://www.wikihow.com>
- [www.morgandowney.com](http://www.morgandowney.com)



## Book Reviewed by:

- Saleh Muqem  
Team Leader Drilling Operational Support, Drilling Operational Support Team
- Mein Maglalang  
Engineer Drilling & Workover, Deep Drilling Group Admin.
- Dr. Mohammed El-Sayed Mohammed Osman  
Consultant, Research & Technology Subsurface Team
- Fathi Atta  
Snr. Drilling Engineer, Drilling & Workover Technical Services Team II
- Richard Morris  
Senior HSE Advisor, Health Safety & Environment Team
- Ashok Garlapati, CSP, QEP, CMIOSH  
HSE Consultant, Health Safety & Environment Team
- Garry Gopaul  
Specialist, Health Safety & Environment Team
- Jack Lusk  
Senior Specialist, Health Safety & Environment Team (D&T)
- Gino Jose  
HSE Engineer, Health Safety & Environment Team (D&T)
- Bashir Ahmad Malik  
Senior Drilling Hygienist, Health Safety & Environment Team (D&T)



# Copyright

Fahad Al-Dhamen

Oil Drops

© 2013, Fahad Al-Dhamen

faldhamen@gmail.com

ALL RIGHTS RESERVED. This book contains material protected under International and Federal Copyright Laws and Treaties. Any unauthorized reprint or use of this material is prohibited. No part of this book may be reproduced or transmitted in any form or by any means, electronic or mechanical, including photocopying, recording, or by any information storage and retrieval system without express written permission from the author / publisher.



# Notes

A series of horizontal dashed lines spanning the width of the page, intended for writing notes.



# Notes

A series of horizontal dashed lines for writing notes.



# Notes

A series of horizontal dashed lines for writing notes, spanning the width of the page.







إحدى شركات مؤسسة البترول الكويتية  
A Subsidiary of Kuwait Petroleum Corporation